

Data sheet

Solenoid valve

Type EVR 2 - EVR 40 Version 2



EVR is a direct or servo operated solenoid valve suitable for liquid, suction, and hot gas lines with most refrigerants, including flammable refrigerants. EVR valves and coils are sold separately.

Features

- Complete range of solenoid valves for refrigeration, freezing and air conditioning plant
- Supplied in versions normally closed (NC) and normally open (NO) with de-energized coil
- Wide choice of coils for AC and DC
- Suitable for most refrigerants, including flammable refrigerants
- Designed for media temperatures up to 221 °F
- Flare connections up to $\frac{5}{8}$ in
- Solder connections up to $2\frac{1}{8}$ in
- Extended ends on solder versions make the installation easy, eliminating the need to dismantle the valve when soldering in
- Available in flare, solder and flange connection versions

Approvals

- Pressure Equipment Directive (PED) 2014/68/EU
- Low Voltage Directive (LVD) 2014/35/EU
- UL429 General Purpose Valve
- EAC
- UA
- ATEX zone 2
- CQC
- RoHS II
- For Marine approvals: Contact Danfoss for latest updates

Table of contents	Technical data.....	3
	Rated capacity [TR].....	4
	Ordering.....	5
	EVR solder connection (NC).....	5
	EVR solder connection (NO).....	6
	EVR flare connection (NC).....	6
	EVR flare connection (NO).....	6
	EVR flange connection (NC).....	7
	EVRC solder connection (NC).....	7
	BJ and BX coils.....	8
	BG coils.....	9
	Function.....	10
	Design and material specifications.....	11
	EVR 2 - EVR 3 solder and flare connection.....	11
	EVR 4 - EVR 6 - EVR 8 solder and flare connection.....	12
	EVR 10 solder and flare connection.....	13
	EVR 15 - EVR 18 solder, flare and flange connection.....	14
	EVR 20 - EVR 22 solder and flange connection.....	15
	EVR 25 solder connection.....	16
	EVR 32 - EVR 40 solder connection.....	17
	EVRC solder connection.....	18
	Dimensions and weights.....	19
	EVR 2 - EVR 3 solder connection.....	19
	EVR 4 - EVR 6 - EVR 8 solder connection.....	20
	EVR 10 solder connection.....	21
	EVR 15 - EVR 18 solder connection.....	22
	EVR 20 - EVR 22 solder connection.....	23
	EVR 25 solder connection.....	24
	EVR 32 - EVR 40 solder connection.....	25
	EVRC 15 solder connection.....	26
	EVRC 20 solder connection.....	27
	EVR 2 - EVR 3 flare connection.....	28
	EVR 6 flare connection.....	29
	EVR 10 flare connection.....	30
	EVR 15 flare connection.....	31
	EVR 15 flange connection.....	32
	EVR 20 flange connection.....	33
	Extended capacity, Liquid.....	34
	Extended capacity, Suction.....	37
	Extended capacity, Hot gas.....	49

Technical data
Refrigerants

R22/R407C, R134a, R404A/R507, R410A, R407A, R32, R290, R600, R600a, R1234yf, R1234ze, R407F, R125, R152A, R448A, R449A, R452A, and R450A. For a complete list of approved refrigerants, visit www.products.danfoss.com and search for individual code numbers, where refrigerants are listed as part of technical data.

Special note for R152A, R32, R290, R600, R600a, R1234yf, and R1234ze:

This product is validated in accordance to ATEX, ISO 5149, IEC 60335, and UL. Ignition risk is evaluated in accordance to ISO 5149 and IEC 60335. See safety note at the bottom of this page.

Media temperature

-40 – 221 °F
Max. 266 °F during defrosting

Ambient temperature and enclosure for coil

See separate data sheet for solenoid and ATEX coils.

Max. working pressure

EVR solder and flare connections: 655 psi.
EVR flange connections: 460 psi.

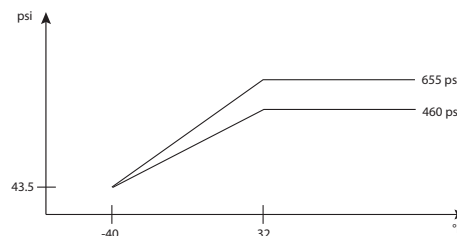

Max. working pressure in bar in relation to media temperature in °F.

Capacity

See extended capacity tables later in this data sheet.

Type	Opening differential pressure with standard coil Δp [psi]		
	Min.	Max. (= MOPD) liquid	
		AC coil [14-17 W]	DC coil [20 W]
EVR 2 NC	0	550	478
EVR 3 NC	0	550	261
EVR 4 NC	0.44	550	406
EVR 6 NC	0.44	550	406
EVR 6 NO	0.44	305	305
EVR 8 NC	0.44	550	406
EVR 10 NC	0.44	550	290
EVR 10 NO	0.44	305	305
EVR 15 NC	0.44	550	290
EVR 15 NO	0.44	305	305
EVR 18 NC	0.44	550	290
EVR 20 NC	0.44	550	290
EVR 20 NO	0.44	276	276
EVR 22 NC	0.44	550	290
EVR 22 NO	0.44	276	276
EVR 25 NC	2.9	450	246
EVR 32 NC	2.9	450	246
EVR 40 NC	2.9	450	246



The EVR 2 - EVR 22 with solder connections and without manual stem can be applied on systems with R152A, R32, R290, R600, R600a, R1234yf, and R1234ze as the working fluid.

For countries where safety standards are not an indispensable part of the safety system Danfoss recommends the installer gets a third party approval of any system containing flammable refrigerant.

Note: please follow specific selection criteria stated in the datasheet for these particular refrigerants.

Data sheet | Solenoid valve, types EVR 2 - EVR 40 Version 2
**Rated capacity [TR]
For other refrigerants, refer
to Coolselector®2**

Type	R22/R407C	R134a	R404A/R507	R410A	R32	R290	R600a
Liquid							
EVR 2	0.92	0.85	0.59	0.86	1.25	1.03	1.06
EVR 3	1.66	1.54	1.07	1.55	2.26	1.85	1.91
EVR 4	4.18	3.87	2.68	3.9	5.69	4.65	4.81
EVR 6	5.47	5.07	3.51	5.11	7.44	6.08	6.3
EVR 8	6.52	6.03	4.18	6.08	8.87	7.25	7.5
EVR 10	11.5	10.64	7.38	10.73	15.64	12.78	13.24
EVR 15	17.71	16.39	11.37	16.53	24.09	19.68	20.39
EVR 18	23.18	21.46	14.88	21.64	31.53	25.77	26.69
EVR 20	36.76	34.04	23.6	34.32	50.01	40.87	42.33
EVR 22	41.93	38.82	26.92	39.14	57.04	46.61	48.28
EVR 25	60.19	55.72	38.64	56.18	-	-	-
EVR 32	102.85	95.23	66.03	96.01	-	-	-
EVR 40	148.77	137.75	95.51	138.88	-	-	-
Suction vapour							
EVR 2	0.08	0.06	0.06	0.09	0.12	0.09	0.06
EVR 3	0.14	0.11	0.12	0.17	0.22	0.17	0.1
EVR 4	0.35	0.27	0.29	0.42	0.55	0.42	0.26
EVR 6	0.46	0.35	0.38	0.55	0.72	0.55	0.34
EVR 8	0.55	0.41	0.46	0.66	0.86	0.66	0.4
EVR 10	0.96	0.73	0.8	1.16	1.51	1.16	0.71
EVR 15	1.48	1.13	1.24	1.79	2.32	1.79	1.1
EVR 18	1.94	1.47	1.62	2.34	3.04	2.34	1.44
EVR 20	3.08	2.34	2.57	3.71	4.82	3.71	2.28
EVR 22	3.51	2.67	2.93	4.23	5.5	4.24	2.61
EVR 25	4.67	3.5	3.9	5.65	-	-	-
EVR 32	7.97	5.99	6.66	9.65	-	-	-
EVR 40	11.53	8.66	9.63	13.96	-	-	-
Hot gas							
EVR 2	0.21	0.17	0.18	0.25	0.33	0.25	0.16
EVR 3	0.37	0.30	0.32	0.46	0.59	0.44	0.29
EVR 4	0.94	0.76	0.82	1.16	1.48	1.12	0.73
EVR 6	1.23	0.99	1.07	1.51	1.94	1.46	0.95
EVR 8	1.47	1.18	1.27	1.80	2.31	1.74	1.13
EVR 10	2.59	2.09	2.25	3.18	4.07	3.07	2.00
EVR 15	4.00	3.22	3.46	4.89	6.26	4.73	3.08
EVR 18	5.23	4.21	4.53	6.40	8.20	6.19	4.03
EVR 20	8.30	6.69	7.18	10.16	13.01	9.81	6.40
EVR 22	9.46	7.62	8.19	11.59	14.83	11.19	7.30
EVR 25	13.58	10.94	11.76	16.63	-	-	-
EVR 32	23.21	18.70	20.09	28.42	-	-	-
EVR 40	33.58	27.05	29.06	41.11	-	-	-

Capacities are based on:
Pressure drop across valve: 3.00 psi
Liquid temperature: 100.0 °F
Subcooling: 10.0 °F
Evaporating temperature: 40.0 °F
Superheat: 0 °F

Capacities are based on:
Pressure drop across valve: 1.00 psi
EVR 25, EVR 32, EVR 40: 2.00 psi
Liquid temperature: 100.0 °F
Subcooling: 10.0 °F
Evaporating temperature: 40.0 °F
Superheat: 0 °F

Capacities are based on:
Pressure drop across valve: 3.00 psi
Condensing temperature: 100.0 °F
Subcooling: 10.0 °F
Hot gas temperature = tc +: 40.0 °F
Evaporating temperature: 40.0 °F
Superheat: 0 °F

Data sheet | Solenoid valve, types EVR 2 - EVR 40 Version 2
**Ordering
EVR solder connection,
Normally Closed (NC)
- separate valve bodies**

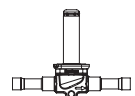

EVR 2 / EVR 3

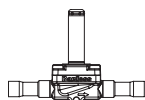

EVR 4 / EVR 6 / EVR 8

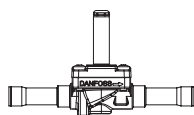

EVR 10



EVR 15 / EVR 18 / EVR 20 / EVR 22

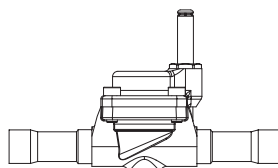

EVR 25

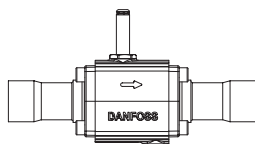

EVR 32 / EVR 40

Type	Coil voltage	Connection size [in]	Connection size [mm]	Manual operation	Code no.
EVR 2	AC / DC	1/4	–	No	032F1201
	AC / DC	1/4	–	No	032F7100
	AC / DC	–	6	No	032F1202
EVR 3	AC / DC	1/4	–	No	032F1206
	AC / DC	3/8	–	No	032F1204
	AC / DC	–	6	No	032F1207
EVR 4	AC / DC	–	10	No	032F1208
	AC / DC	3/8	–	No	032L7110
	AC / DC	3/8	–	No	032L1212
EVR 6	AC / DC	3/8	–	Yes	032L7116
	AC / DC	–	10	No	032L1213
	AC / DC	–	12	No	032L1236
	AC / DC	1/2	–	No	032L1209
	AC / DC	1/2	–	Yes	032L7144
	AC / DC	5/8	–	No	032L7117
EVR 8	AC / DC	1/2	–	No	032L7121
	AC / DC	1/2	–	Yes	032L7148
	AC / DC	5/8	–	No	032L7122
EVR 10	AC / DC	3/8	–	No	032L7125
	AC / DC	–	12	No	032L1218
	AC / DC	1/2	–	No	032L1217
	AC / DC	1/2	–	Yes	032L1188
	AC / DC	5/8	16	No	032L1214
	AC / DC	5/8	–	Yes	032L7149
EVR 15	AC / DC	5/8	16	No	032L1228
	AC / DC	5/8	16	Yes	032L1227
EVR 18	AC / DC	7/8	22	No	032L1225
	AC / DC	7/8	–	Yes	032L1004
EVR 20	AC / DC	7/8	–	No	032L1240
	AC / DC	7/8	–	Yes	032L1254
	AC / DC	1 1/8	–	No	032L1244
	AC / DC	–	28	No	032L1245
EVR 22	AC / DC	1 1/8	–	No	032L7145
	AC / DC	1 1/8	–	Yes	032L7137
	AC / DC	1 3/8	–	No	032L3267
EVR 25	AC / DC	1 1/8	–	Yes	032L2200
	AC / DC	1 1/8	–	No	032L2201
	AC / DC	–	28	Yes	032L2205
	AC / DC	–	28	No	032L2206
	AC / DC	1 3/8	–	Yes	032L2207
	AC / DC	1 3/8	–	No	032L2208
EVR 32	AC / DC	1 3/8	35	Yes	032L1105
	AC / DC	1 3/8	35	No	032L1106
	AC / DC	1 5/8	–	Yes	032L1103
	AC / DC	1 5/8	–	No	032L1104
	AC / DC	–	42	Yes	032L1107
	AC / DC	–	42	No	032L1108
EVR 40	AC / DC	2 1/8	–	No	032L1180
	AC / DC	2 1/8	–	Yes	032L1181
	AC / DC	1 5/8	–	Yes	032L1109
	AC / DC	1 5/8	–	No	032L1110
	AC / DC	–	42	Yes	032L1113
	AC / DC	–	42	No	032L1114
	AC / DC	2 1/8	–	Yes	032L1111
AC / DC	2 1/8	–	No	032L1112	

See separate data sheet for coils

Data sheet | Solenoid valve, types EVR 2 - EVR 40 Version 2

Ordering EVR solder connection, Normally Open (NO) - separate valve bodies

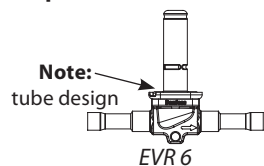

Type	Coil voltage	Connection size [in]	Connection size [mm]	Manual operation	Code no.
EVR 6	AC / DC	3/8	–	No	032L1290
	AC / DC	–	10	No	032L1295
EVR 10	AC / DC	1/2	–	No	032L1291
	AC / DC	–	12	No	032L1296
EVR 15	AC / DC	5/8	16	No	032L1299
	AC / DC	7/8	–	No	032L3270
EVR 20	AC / DC	7/8	–	No	032L1260
	AC / DC	1 1/8	–	No	032L1269
	AC / DC	–	28	No	032L1279
EVR 22	AC	1 3/8	–	No	032L3268

See separate data sheet for coils

The normal range of coils can be used for the NO valves, with the exception of the double frequency versions of 110 V, 50/60 Hz and 220 V, 50/60 Hz.

Ordering EVR flare connection, Normally Closed (NC) - separate valve bodies

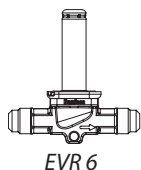

Type	Coil voltage	Connection size [in]	Connection size [mm]	Manual operation	Code no.
EVR 2	AC / DC	1/4	6	No	032F8056
EVR 3	AC / DC	1/4	6	No	032F8107
	AC / DC	3/8	10	No	032F8116
EVR 6	AC / DC	3/8	10	No	032L8072
	AC / DC	1/2	12	No	032L8079
EVR 10	AC / DC	1/2	12	No	032L8095
	AC / DC	5/8	16	No	032L8098
EVR 15	AC / DC	5/8	16	Yes	032L8100
	AC / DC	5/8	16	No	032L8101

See separate data sheet for coils

Ordering EVR flare connection, Normally Open (NO) - separate valve bodies

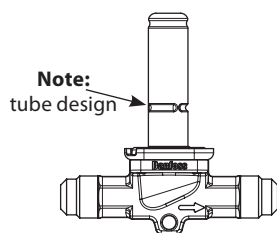

Type	Coil voltage	Connection size [in]	Connection size [mm]	Manual operation	Code no.
EVR 6	AC / DC	3/8	10	No	032L8085
EVR 10	AC / DC	1/2	12	No	032L8090

See separate data sheet for coils

The normal range of coils can be used for the NO valves, with the exception of the double frequency versions of 110 V, 50/60 Hz and 220 V, 50/60 Hz.

Valve bodies are supplied without flare nuts.

Separate flare nuts:

- 1/4 in or 6 mm, code no. **011L1101**
- 3/8 in or 10 mm, code no. **011L1135**
- 1/2 in or 12 mm, code no. **011L1103**
- 5/8 in or 16 mm, code no. **011L1167**

Data sheet | Solenoid valve, types EVR 2 - EVR 40 Version 2

Ordering
EVR flange connection,
Normally Closed (NC)
- separate valve bodies

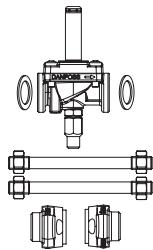

EVR 15

Type	Coil voltage	Connection	Manual operation	Code no.
EVR 15	AC / DC	Flanges	No	032L1224
	AC / DC	Flanges	Yes	032L1234
EVR 20	AC / DC	Flanges	No	032L1243
	AC / DC	Flanges	Yes	032L1253

See separate data sheet for coils

Flange sets

Type	Connection size		Connection type			Code no.
	[in]	[mm]	Solder [in]	Solder [mm]	Weld [in]	
EVR 15	1/2	-	-	-	Yes	027N1115
	5/8	-	Yes	-	-	027L1117
	-	16	-	Yes	-	027L1116
	3/4	-	-	-	Yes	027N1120
	7/8	-	Yes	-	-	027L1123
	-	22	-	Yes	-	027L1122
EVR 20	3/4	-	-	-	Yes	027N1220
	7/8	-	Yes	-	-	027L1223
	-	22	-	Yes	-	027L1222
	1	-	-	-	Yes	027N1225
	1 1/8	-	Yes	-	-	027L1229
	-	28	-	Yes	-	027L1228

See separate data sheet for coils

Example

EVR 15 without manual operation,
code no. **032L1224**

1/2 in weld flange set,
code no. **027N1115**

+ coil with terminal box, 220 V, 50 Hz,
code no. **018F6701**

Ordering
EVRC solder connection,
Normally Closed (NC)
- separate valve bodies

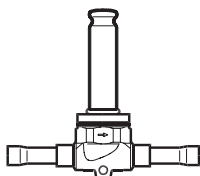

Type	Coil voltage	Connection size [in]	Connection size [mm]	Manual operation	Code no.
EVRC 15	AC / DC	5/8	16	No	032L1255
EVRC 20	AC / DC	7/8	22	No	032L1258

See separate data sheet for coils

BJ and BX coils

Approvals

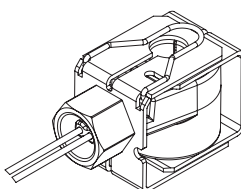
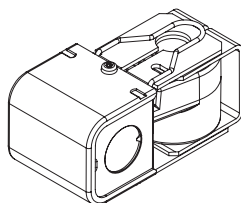
Ordering

Coil type	Wire length		Voltage [V] AC	Frequency [Hz]	Power consumption [W]	Code no.
	[in]	[cm]				
Junction box NEMA 2						
BJ024CS	7	18	24	50 / 60	14	018F4100
BJ120CS	7	18	110-120	60	15	018F4110
	7	18	110	50	16	
BJ240CS	7	18	208 – 240	60	14	018F4120
	7	18	230	50	17	
BJ120BS	7	18	120	60	16	018F4130
BJ208BS	7	18	208	60	16	018F4132
BJ240BS	7	18	240	60	16	018F4134
Conduit boss NEMA 4						
BX024CS	18	46	24	50 / 60	14	018F4102
BX024CS	71	180	24	50 / 60	14	018F4103
BX024CS	98	250	24	50 / 60	14	018F4104
BX120CS	18	46	110-120 110	60 50	15 16	018F4112
BX120CS	36	91				018F4113
BX120CS	71	180				018F4114
BX120CS	98	250				018F4115
BX240CS	18	46	208 – 240	60	14	018F4122
	98	250	230	50	17	018F4123
BX120BS	98	250	120	60	16	018F4131
BX208BS	98	250	208	60	16	018F4133
BX240BS	98	250	240	60	16	018F4135

Technical data

Design
In accordance with UL 429

Power supply
Alternating current (AC)

Permissible voltage variation
Alternating current (AC):
50 Hz and 60 Hz: -10% – +15%
50/60 Hz: +/- 10%

Power consumption
Alternating current (AC): Inrush: 49 VA;
Holding: 28 VA, 14-17 W

Insulation of coil wire
Class H according to IEC 85

Connection
Junction box or Conduit boss

Enclosure. IEC 60529
Junction box NEMA 2 ~ IP 12–32
Conduit boss NEMA 4 ~ IP 54

Ambient temperature
-40 °F – 122 °F (-40 °C – 50 °C)

Data sheet | Solenoid valve, types EVR 2 - EVR 40 Version 2

BG coils



- For high temperatures – class H insulated wire
- Encapsulated coils with long life time
- Wide range of coils
 - from 12 V – 220 V DC
 - with terminal box IP67 ~ NEMA 6

Approvals

Low Voltage Directive (LVD) 2014/35/EU

Ordering

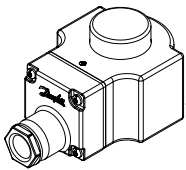

Valve type	Voltage [V] DC	Power consumption [W]	Code no.
EVR 2 to 8 (NC) EVR 25 to 40 (NC/NO) EVR 6 to 8 (NO)	12	20	018F6856
	24	16	018F6857
	48	19	018F6859
	110	16	018F6860
	115	19	018F6861
	220	20	018F6851
EVR 10 to 22 (NC/NO) EVRC 15 to 20	12	20	018F6886
	24	20	018F6887
	48	20	018F6889
	110	20	018F6890
	220	20	018F6881

Technical data

Design
In accordance with VDE 0580

Connection
Terminal box

Power supply
Direct current (DC)

Enclosure. IEC 529
IP 67 NEMA 6

Permissible voltage variation
±10%

Ambient temperature
-40 °F – 122 °F (-40 °C – 50 °C)

Power consumption
16-20 W

Insulation of coil wire
Class H according to IEC 85

Function

EVR solenoid valves are designed on two different principles:

1. Direct operation
2. Servo operation

See *Design and material* drawings for additional details on the following pages

1. Direct operation (NC)

EVR 2 – EVR 3 are direct operated. The valves open directly for full flow when the armature (3) moves up into the magnetic field of the coil.

This means that the valves operate with a minimum differential pressure of 0 bar.

The seat plate is fitted directly on the armature (3).

Inlet pressure acts from above on the armature and the valve plate. Thus, the inlet pressure and spring force act to close the valve when there is no current in the coil.

2. Servo operation (NC)

EVR 4 – EVR 22 are servo operated with a "floating" diaphragm (4). The pilot orifice of stainless steel is placed in the center of the diaphragm. The seat plate is fitted directly to the armature (3). When there is no current in the coil, the main orifice and pilot orifice are closed. The pilot orifice and main orifice are held closed by the armature spring force and the differential pressure between inlet and outlet sides.

When current is applied to the coil, the armature is drawn up into the magnetic field and opens the pilot orifice. This relieves the pressure above the diaphragm, i.e. the space above the diaphragm becomes connected to the outlet side of the valve.

The differential pressure between inlet and outlet sides then presses the diaphragm away from the main orifice and opens it for full flow. Therefore a certain minimum differential pressure is necessary to open the valve and keep it open. For EVR 4 – EVR 22 valves the minimum differential pressure for safe operation is 0.03 bar.

When the current is switched off, the pilot orifice is closed. Via the equalization holes in the diaphragm, the pressure above the diaphragm rises to the same value as the inlet pressure and the diaphragm closes the main orifice.

EVR 25, EVR 32 and EVR 40 are servo operated piston valves. The servo piston (16) with sealing face closes against the valve seat by means of the differential pressure between inlet and outlet side of the valve and the force of the compression spring. When the coil is switched on, the pilot orifice opens. This relieves the pressure on the piston spring side of the valve. The differential pressure will then open the valve. The minimum differential pressure for safe operation is 0.2 bar.

EVR (NO) has the opposite function to EVR (NC), i.e. it is open with de-energized coil.

EVR (NO) is available with servo operation only.

3. Bi-flow operation with EVRC

EVRC is a servo operated solenoid valve with a special diaphragm with built-in non-return valve. The valve is for use in liquid lines in refrigeration plants.

EVRC allows flow in both directions and can be used in liquid lines in refrigeration plants with hot gas or gas defrost.

During the refrigeration period EVRC works as a normal solenoid valve, while during defrost it allows the condensed liquid to return to the liquid manifold.

During the defrosting period the coil for EVRC must be energized.

4. Manual stem operation for EVR 6 - EVR 25 NC

EVR 6 - EVR 25 NC are available with optional manual stem operation to manually force the NC valve open when the coil is de-energized.

The protective cap should be removed and the manual stem (12) should be rotated until the valve is fully open. It takes approx. 6 cycles from fully closed, to reach the fully open position.

After manual operation is completed, the valve should manually be closed again and the protective cap mounted.

Alternatively, all EVR NC and NO valves can be manually operated by removing the coil and force the valve open or closed by using a solenoid valve tester (permanent magnet) code no. 018F0091.

Design and material specifications

**EVR 2 - EVR 3
Solder and flare connection**

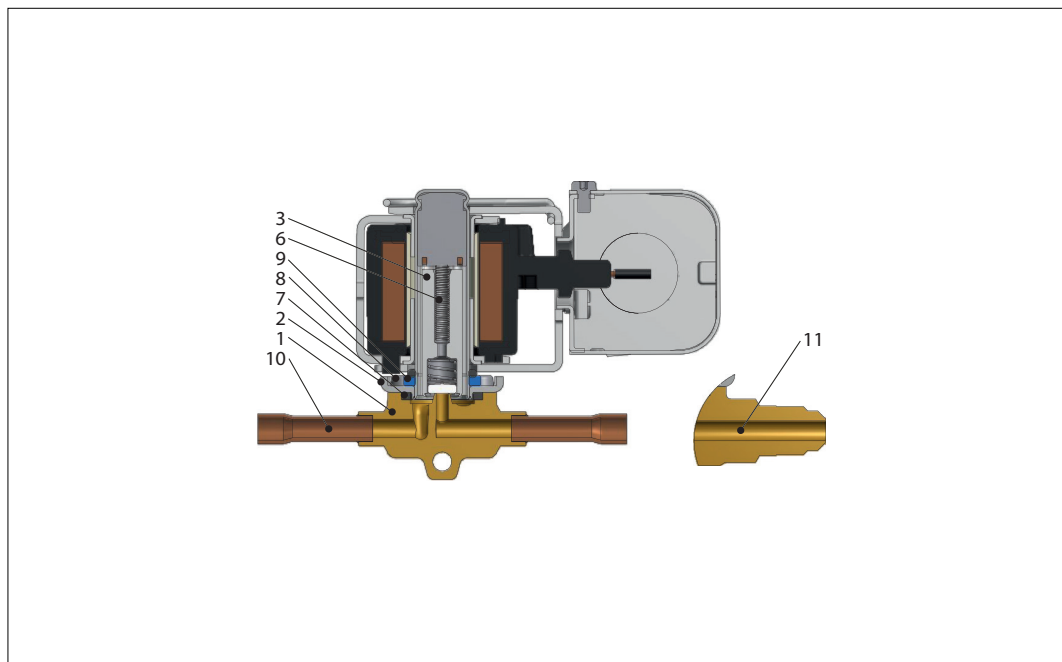

Pos. no.	Description	Material
1	Valve assembly housing	Brass, copper
2	Cover assembly	Stainless steel
3	Armature assembly	Stainless steel/PTFE
6	Armature spring	Stainless steel
7	Seal	Chloroprene rubber
8	Screw	Stainless steel
9	O-ring	EPDM Rubber
10	Solder connection	Copper
11	Flare connection	Brass

Design and material specifications

**EVR 4 - EVR 6 - EVR 8
Solder and flare connection**

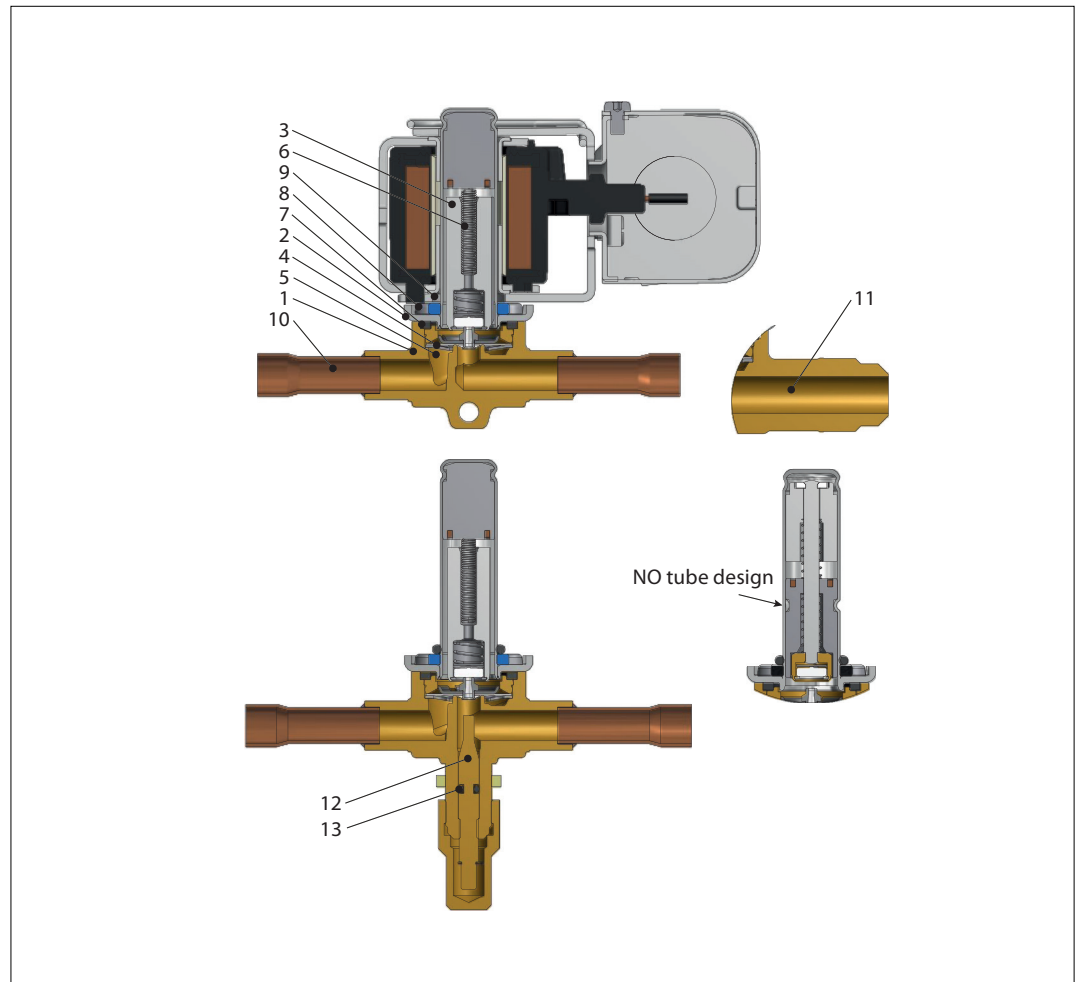

Pos. no.	Description	Material
1	Valve housing assembly	Brass
2	Cover	Stainless steel
3	Armature assembly	Stainless steel/PTFE
4	Diaphragm assembly	Stainless steel/PTFE
5	Support washer	Stainless steel
6	Armature spring	Stainless steel
7	Seal	Chloroprene rubber
8	Screws	Stainless steel
9	O-ring	EPDM rubber
10	Solder connection	Copper
11	Flare connection	Brass
12	Manual stem ¹⁾	Brass
13	O-ring	Chloroprene rubber

¹⁾ Manual stem is not available for EVR 4

Design and material specifications

**EVR 10
Solder and flare connection**

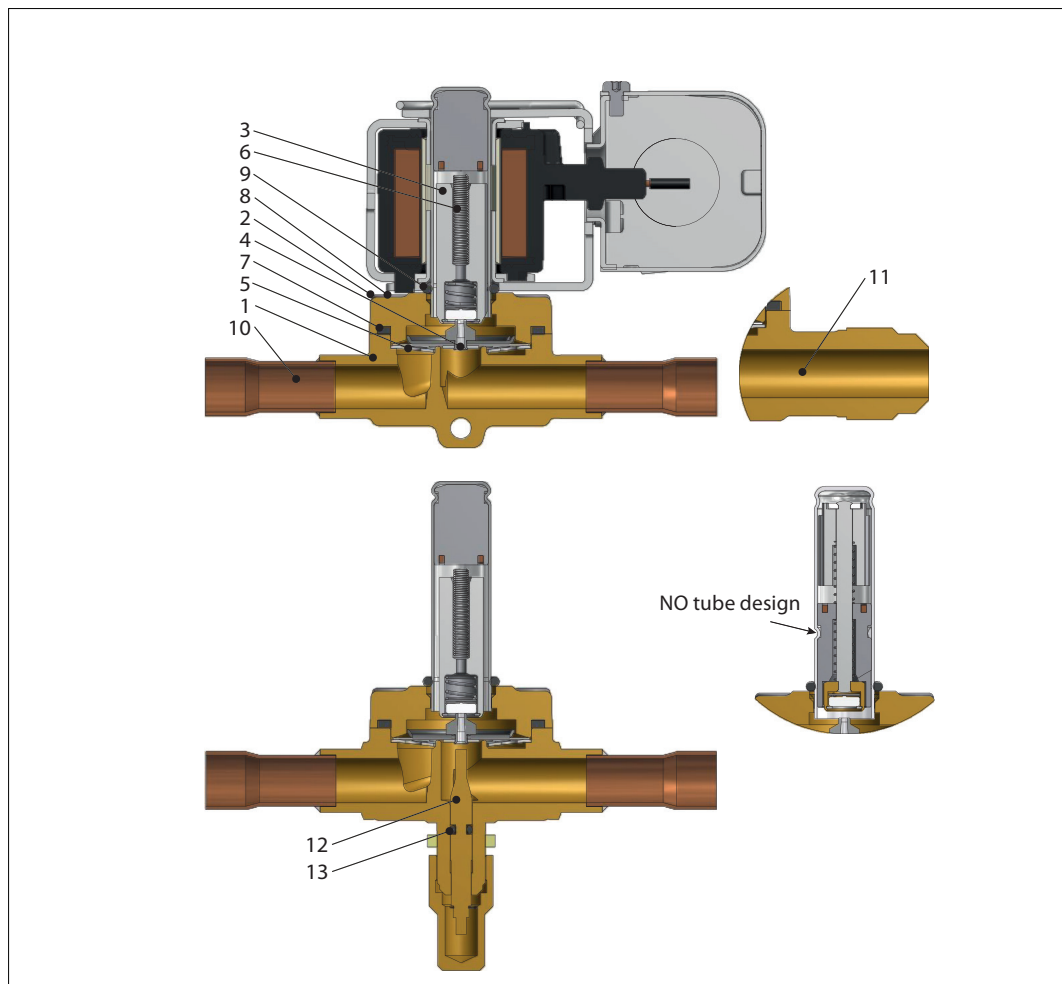

Pos. no.	Description	Material
1	Valve body	Brass
2	Cover	Brass
3	Armature assembly	Stainless steel/PTFE
4	Diaphragm assembly	Stainless steel/PTFE
5	Support washer	Stainless steel
6	Armature spring	Stainless steel
7	Seal	Chloroprene rubber
8	Screws	Stainless steel
9	O-ring	EPDM rubber
10	Solder connection	Copper
11	Flare connection	Brass
12	Manual stem	Brass
13	O-ring	Chloroprene rubber

Design and material specifications

EVR 15 - EVR 18
Solder, flare, and flange connection

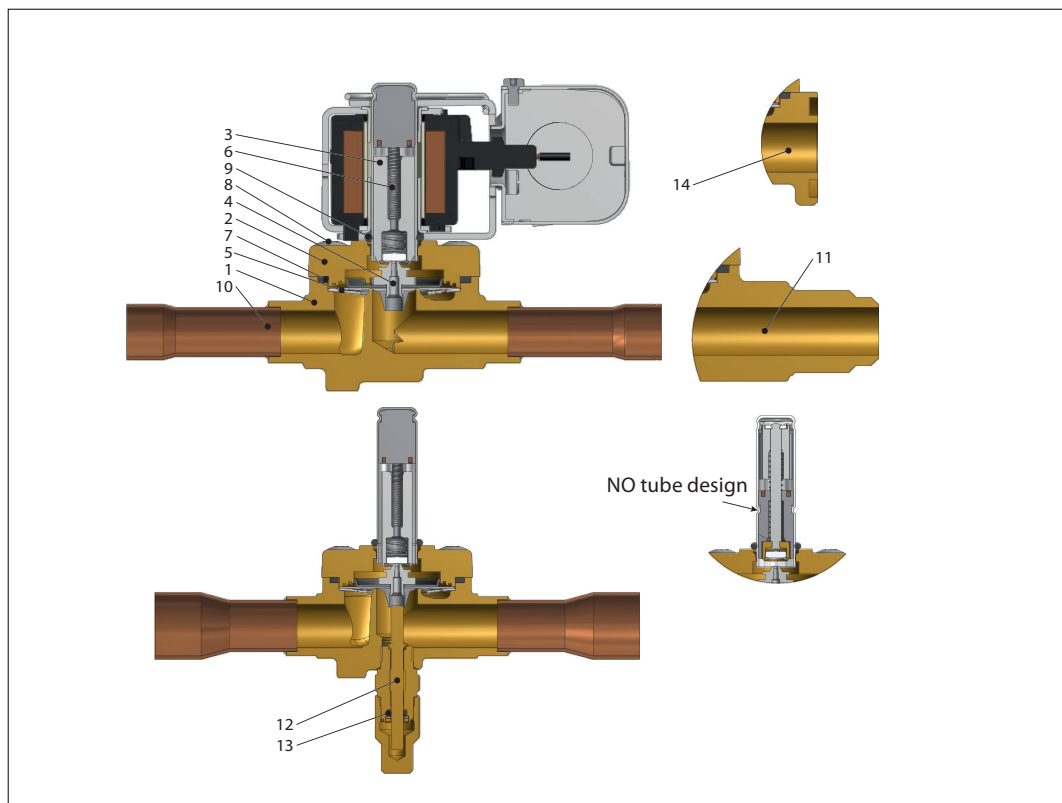

Pos. no.	Description	Material
1	Valve body	Brass
2	Cover	Brass
3	Armature assembly	Stainless steel/PTFE
4	Diaphragm assembly	Stainless steel/PTFE
5	Support washer	Stainless steel
6	Armature spring	Stainless steel
7	Seal	Chloroprene rubber
8	Screws	Stainless steel
9	O-ring	EPDM rubber
10	Solder connection	Copper
11	Flare connection	Brass
12	Manual stem	Brass
13	O-ring	Chloroprene rubber
14	Flange connection	Brass

Design and material specifications

**EVR 20 - EVR 22
Solder and flange connection**

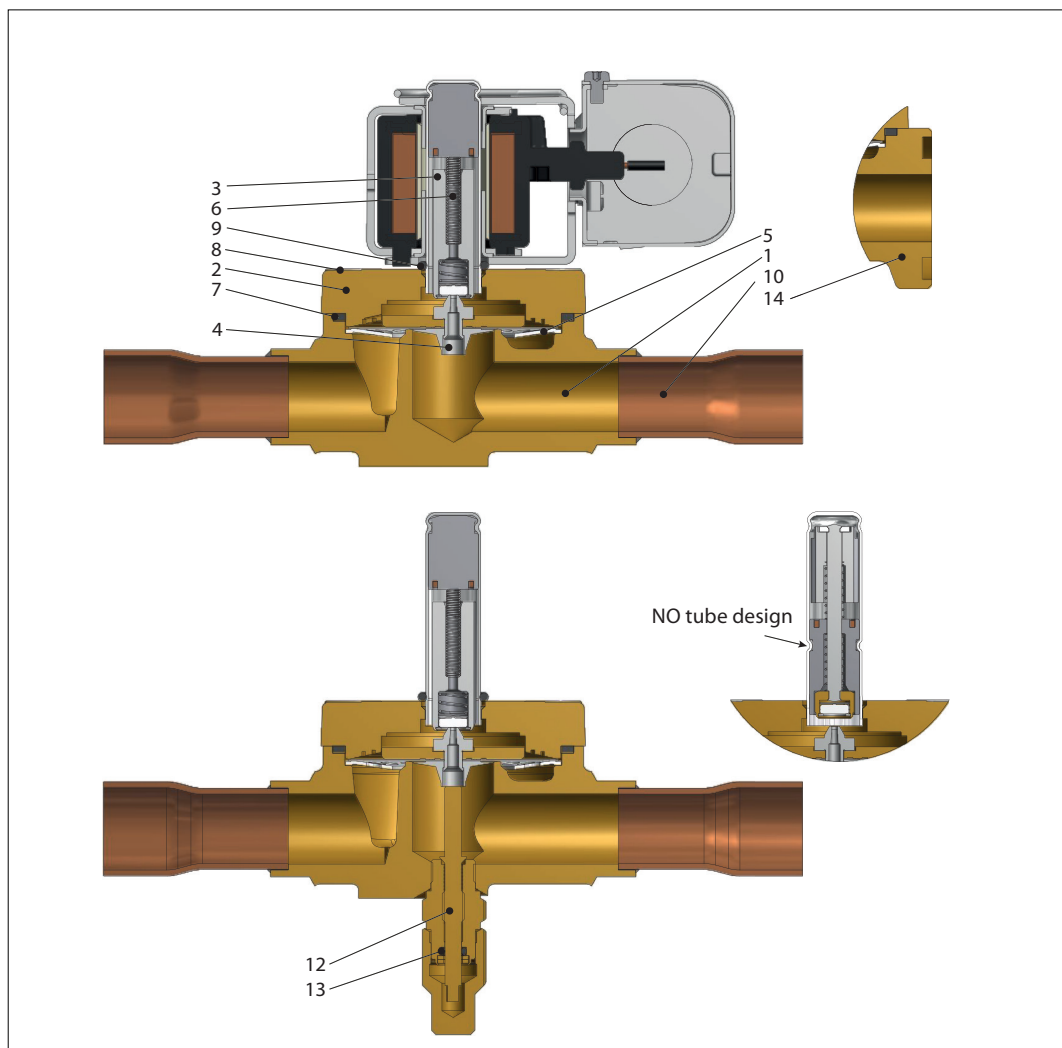

Pos. no.	Description	Material
1	Valve body	Brass
2	Cover	Brass
3	Armature assembly	Stainless steel/PTFE
4	Diaphragm assembly	Stainless steel/PTFE
5	Support washer	Stainless steel
6	Armature spring	Stainless steel
7	Seal	Chloroprene rubber
8	Screws	Stainless steel
9	O-ring	EPDM rubber
10	Solder connection	Copper
12	Manual stem	Brass
13	O-ring	Chloroprene rubber
14	Flange connection	Brass

Design and material specifications

EVR 25
Solder connection

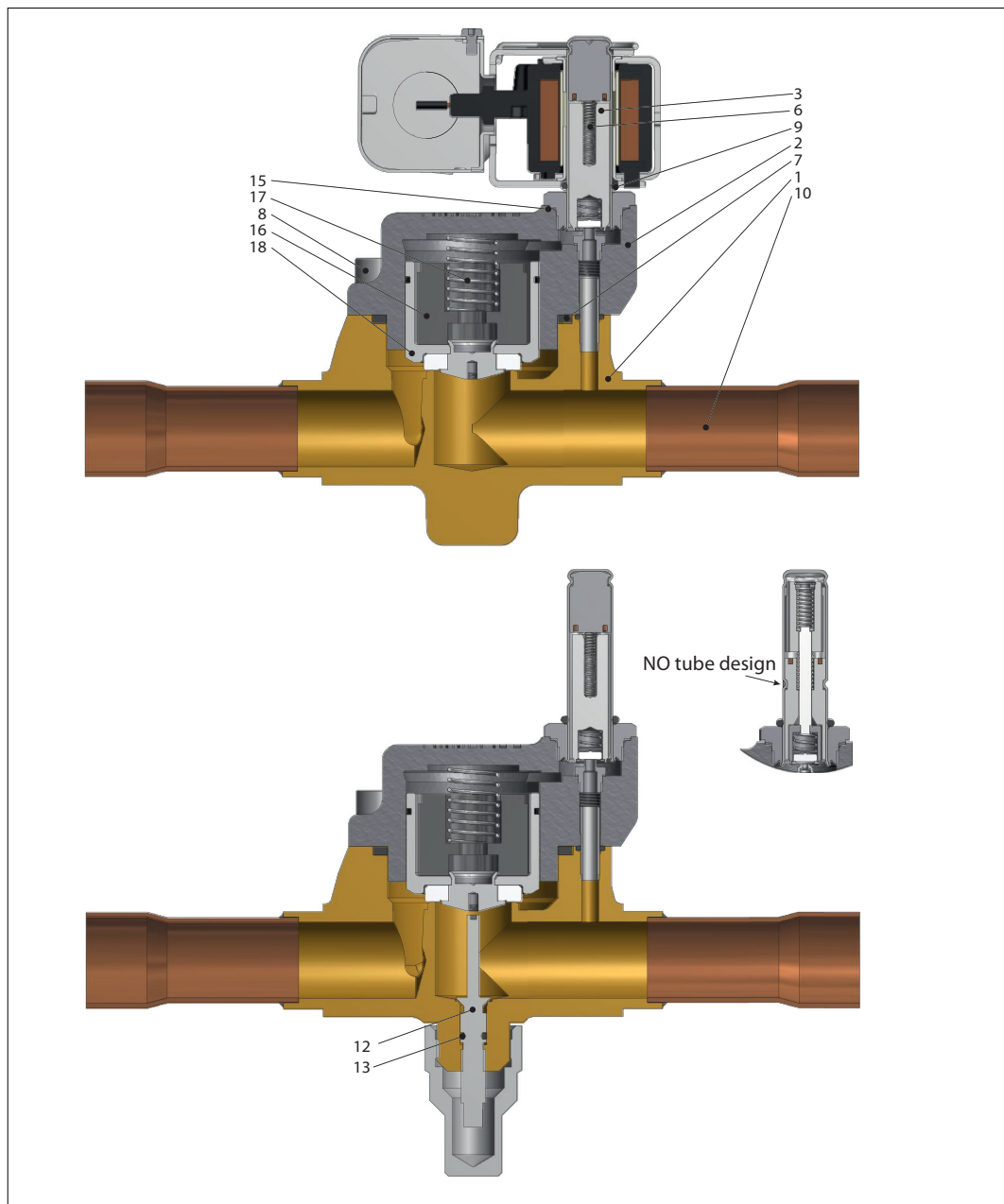

Pos. no.	Description	Material
1	Valve body	Brass
2	Cover	Cast iron
3	Armature assembly	Stainless steel/PTFE
6	Armature spring	Stainless steel
7	Gasket	Chloroprene rubber
8	Screws	Stainless steel
9	O-ring	EPDM rubber
10	Solder connection	Copper
12	Manual stem	Brass
13	O-ring	Chloroprene rubber
15	Gasket	Aluminum
16	Insert	Nylon
17	Piston spring	Stainless steel
18	Piston	Stainless steel

Design and material specifications

**EVR 32 - EVR 40
Solder connection**

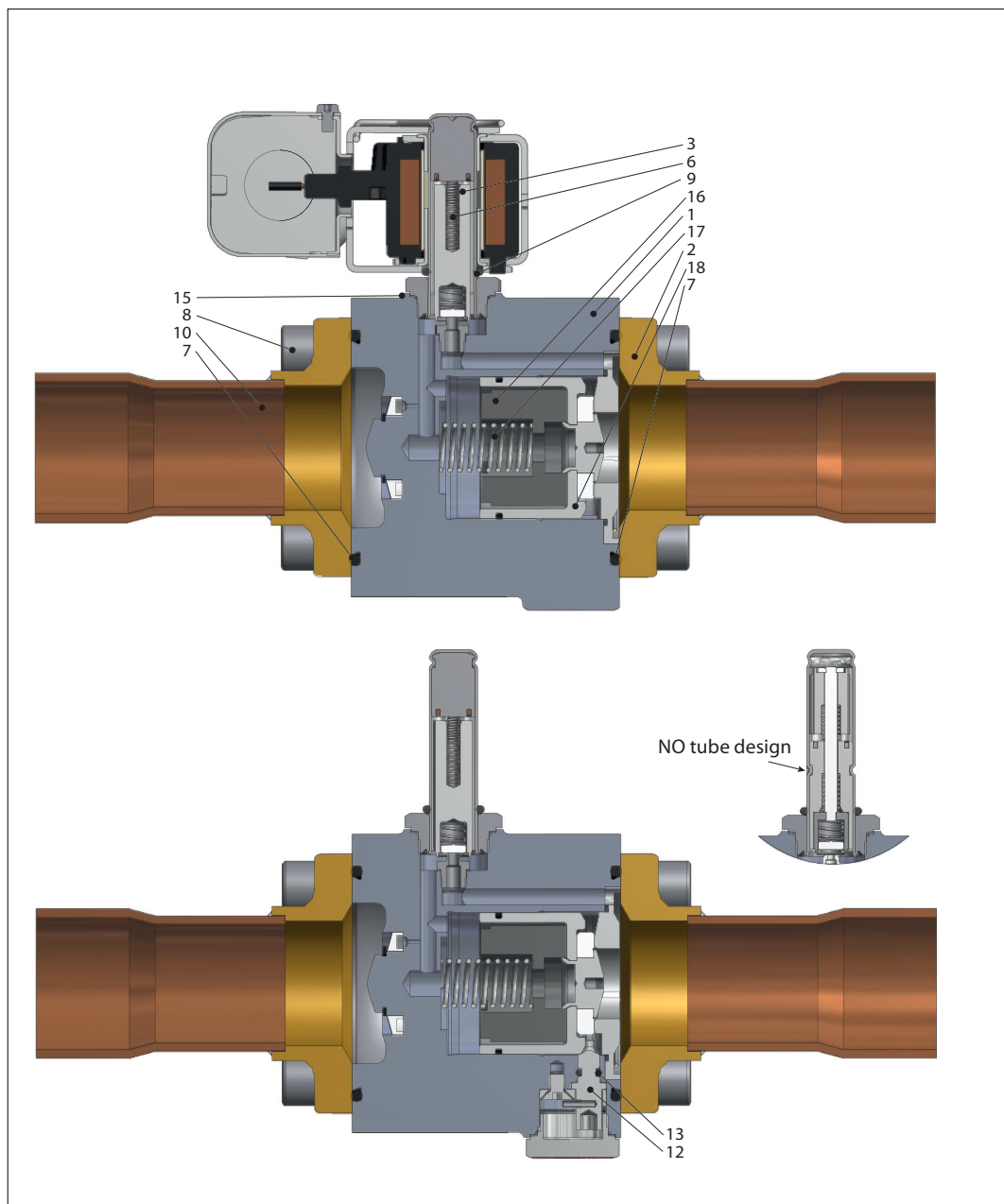

Pos. no.	Description	Material
1	Valve body	Cast iron
2	Cover	Brass
3	Armature assembly	Stainless steel
6	Armature spring	Stainless steel
7	Gasket	Chloroprene rubber
8	Screws	Stainless steel
9	O-ring	EPDM rubber
10	Solder connection	Copper
12	Manual stem	Brass
13	O-ring	Chloroprene rubber
15	Gasket	Aluminum
16	Insert	Nylon
17	Piston spring	Stainless steel
18	Piston	Stainless steel

Design and material specifications

EVRC
Solder connection

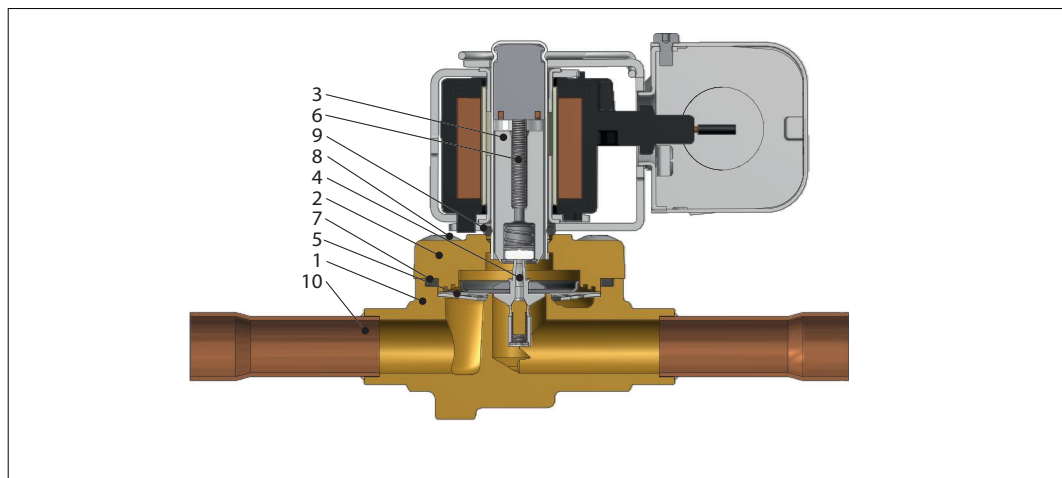

Pos. no.	Description	Material
1	Valve body	Brass
2	Cover	Brass
3	Armature assembly	Stainless steel/PTFE
4	Diaphragm assembly	Stainless steel/PTFE
5	Support washer	Stainless steel
6	Armature spring	Stainless steel
7	Gasket	Chloroprene rubber
8	Screws	Stainless steel
9	O-ring	EPDM rubber
10	Solder connection	Copper

Dimensions and weights

EVR 2 - EVR 3
Solder connection

Conduit hub ¹⁾

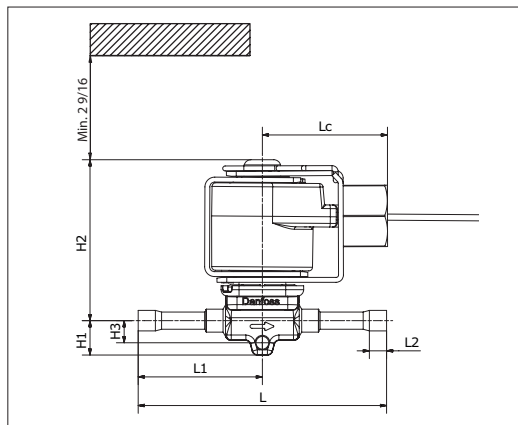

Junction box ²⁾

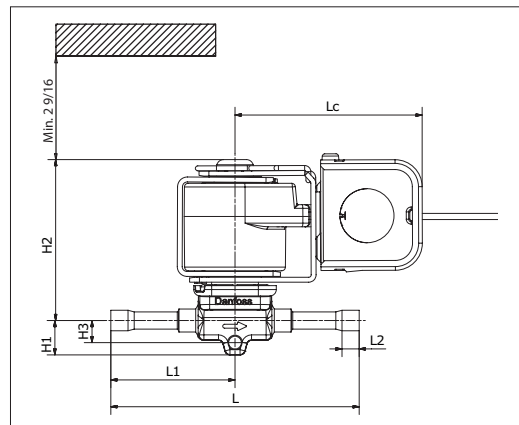

Terminal box ³⁾

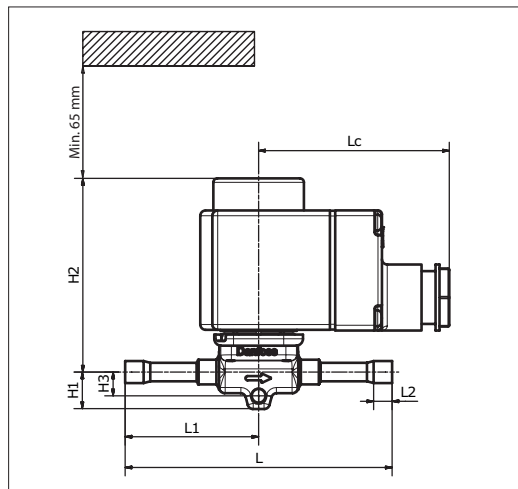

End view

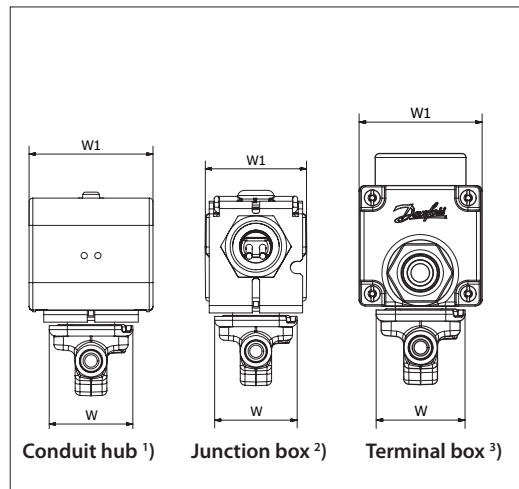

Type	Connection		H ₁ [in]	H ₂ [in]	H ₃ [in]	L [in]	L ₁ [in]	L ₂ [in]	L _c [in]	W [in]	W ₁ max. [in]	Net weight without coil [lbs]
	[in]	[mm]										
EVR 2	1/4	6	0.55	2.87	0.35	3.98	1.99	0.28	–	1.34	–	0.35
EVR 3	1/4	6	0.55	73	0.35	3.98	1.99	0.28	–	1.34	–	0.35
	3/8	10	0.55	73	0.35	4.61	2.30	0.31	–	1.34	–	0.37
Cable coil ¹⁾									1.93	–	1.81	–
DIN plug coil ²⁾									2.52	–	1.85	–
Terminal box coil 10 W ³⁾									2.83	–	1.85	–
Terminal box coil 12 / 20 W ³⁾									3.15	–	2.68	–

Conduit hub: 0.72 lbs

Junction box: 0.86 lbs

Terminal box: 1.10 lbs

For CAD models on individual code numbers, visit www.danfoss.com/products/categories/

Dimensions and weights

EVR 4 - EVR 6 - EVR 8
Solder connection

Conduit hub ¹⁾

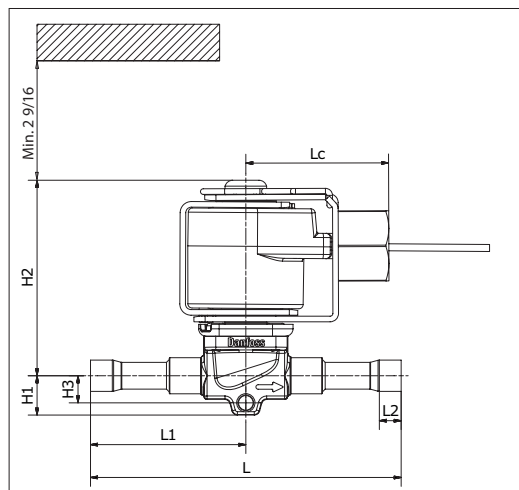

Junction box ²⁾

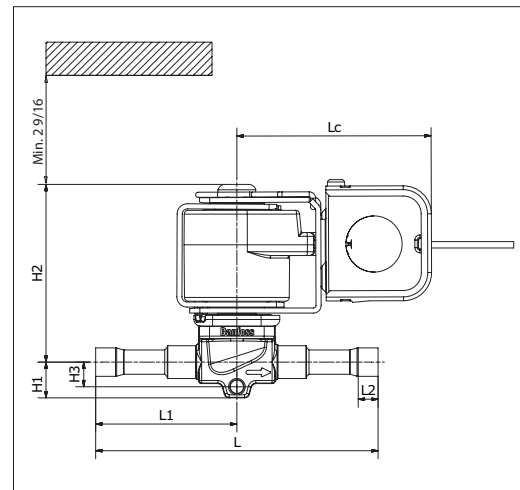

Terminal box ³⁾

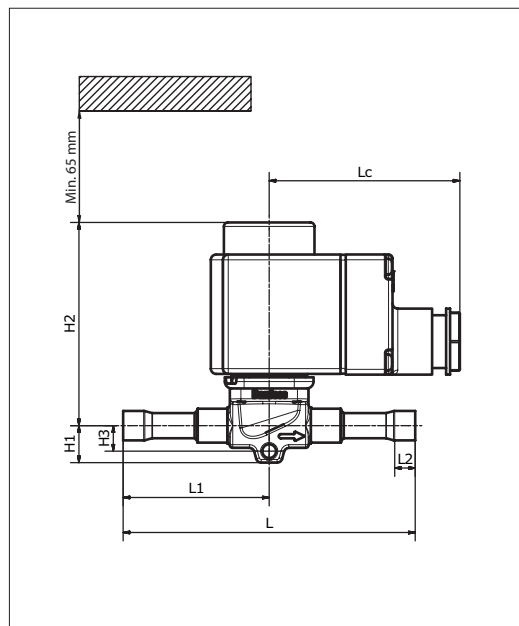

Manual stem

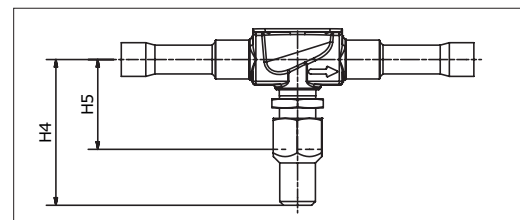

End view

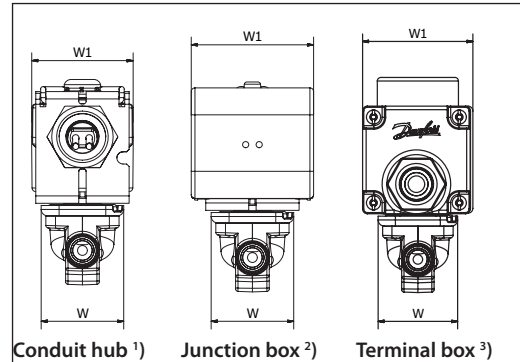

Type	Connection		Manual operation	H ₁	H ₂	H ₃	H ₄	H ₅	L	L ₁	L ₂	L _c	W	W ₁ max.	Net weight without coil [lbs]
	[in]	[mm]		[in]	[in]	[in]	[in]	[in]	[in]	[in]	[in]	[in]			
EVR 4	3/8	10	No	0.55	3.07	0.39	—	—	4.61	2.30	0.31	—	1.34	—	0.42
EVR 6	3/8	10	Yes	0.55	3.07	0.39	1.89	1.18	4.61	2.30	0.31	—	1.34	—	0.42
	3/8	10	No	0.55	3.07	0.39	—	—	4.37	2.19	0.31	—	1.34	—	0.42
	1/2	12	Yes	0.55	3.07	0.39	1.89	1.18	5	2.50	0.39	—	1.34	—	0.44
	1/2	12	No	0.55	3.07	0.39	—	—	5	2.50	0.39	—	1.34	—	0.44
EVR 8	1/2	12	Yes	0.55	3.07	0.39	1.89	1.18	5	2.50	0.39	—	1.34	—	0.44
	1/2	12	No	0.55	3.07	0.39	—	—	5	2.50	0.39	—	1.34	—	0.44
	5/8	16	No	0.55	3.07	0.39	—	—	6.42	3.21	0.47	—	1.34	—	0.44
Cable coil ¹⁾												1.93	—	1.81	—
DIN plug coil ²⁾												2.52	—	1.85	—
Terminal box coil 10 W ³⁾												2.83	—	1.85	—
Terminal box coil 12 / 20 W ³⁾												3.15	—	2.68	—

Net weight of coil (approx.)

Conduit hub: 0.72 lbs

Junction box: 0.86 lbs

Terminal box: 1.10 lbs

For 3D models, visit www.danfoss.com/products/categories/

Dimensions and weights

EVR 10
Solder connection

Conduit hub ¹⁾

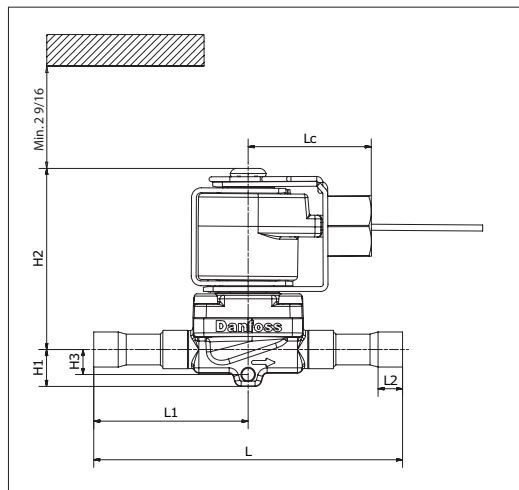

Junction box ²⁾

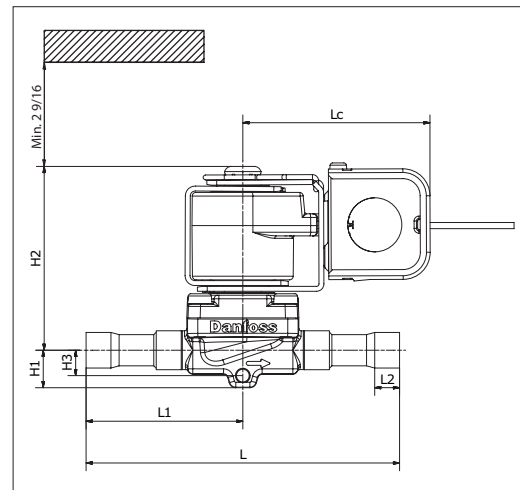

Terminal box ³⁾

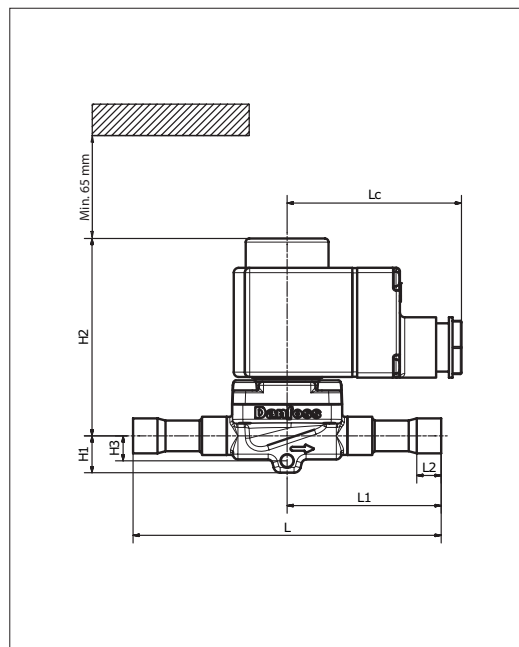

Manual stem

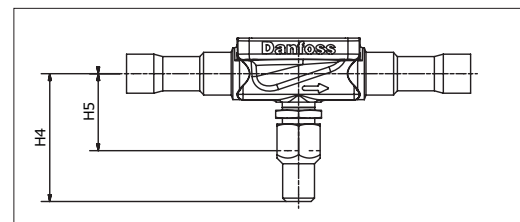

End view

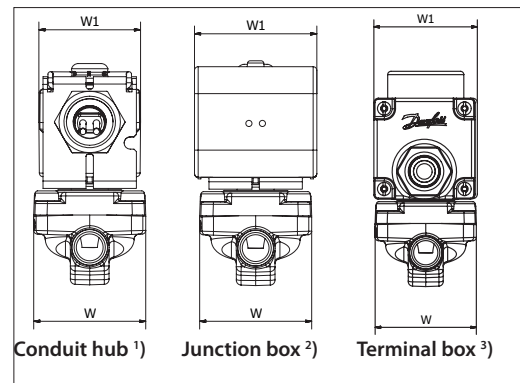

Type	Connection		Manual operation	H ₁ [in]	H ₂ [in]	H ₃ [in]	H ₄ [in]	H ₅ [in]	L [in]	L ₁ [in]	L ₂ [in]	L _c [in]	W [in]	W ₁ max. [in]	Net weight without coil [lbs]
	[in]	[mm]													
EVR 10	1/2	12	Yes	0.59	3.23	0.39	1.89	1.14	5.04	2.52	0.39	-	1.81	-	0.86
	3/8	10	No	0.59	3.23	0.39	-	-	4.65	2.32	-	-	1.81	-	0.75
	5/8	16	No	0.59	3.23	0.39	-	-	6.42	3.21	0.47	-	1.81	-	0.84
	5/8	16	Yes	0.59	3.23	0.39	1.89	1.14	6.42	3.21	0.47	-	1.81	-	0.88
Cable coil ¹⁾												1.93	-	1.81	-
DIN plug coil ²⁾												2.52	-	1.85	-
Terminal box coil 10 W ³⁾												2.83	-	1.85	-
Terminal box coil 12 / 20 W ³⁾												3.15	-	2.68	-

Net weight of coil (approx.)

Conduit hub: 0.72 lbs

Junction box: 0.86 lbs

Terminal box: 1.10 lbs

For 3D models, visit www.danfoss.com/products/categories/

Dimensions and weights

EVR 15 - EVR 18
Solder connection

Conduit hub ¹⁾

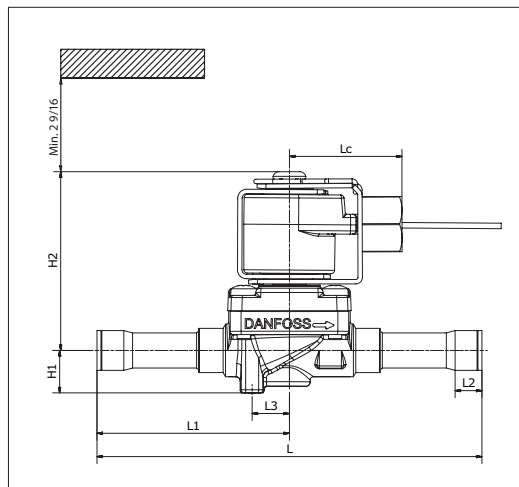

Junction box ²⁾

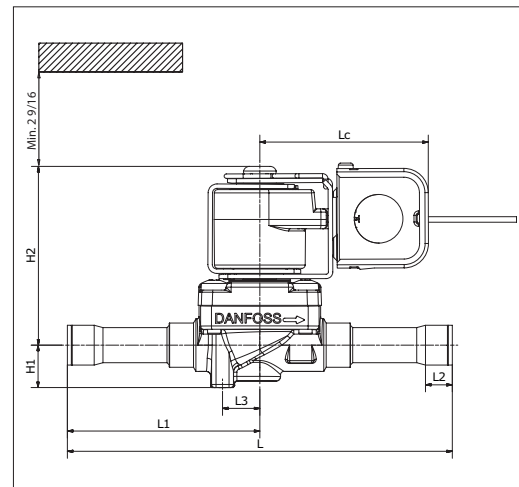

Terminal box ³⁾

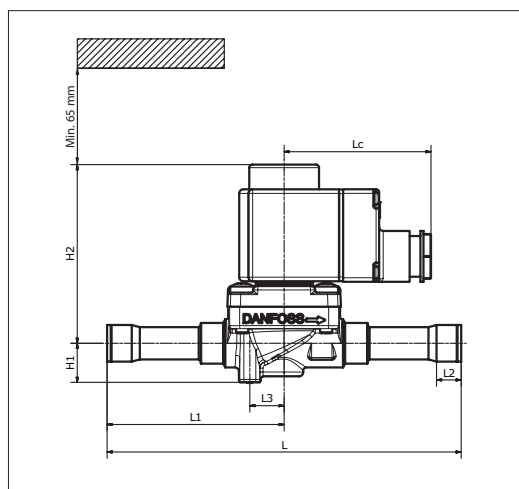

Manual stem

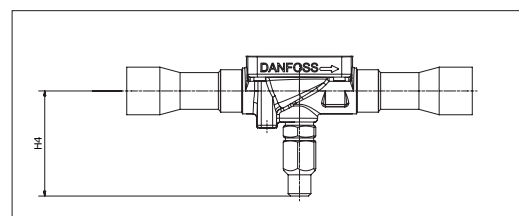

End view

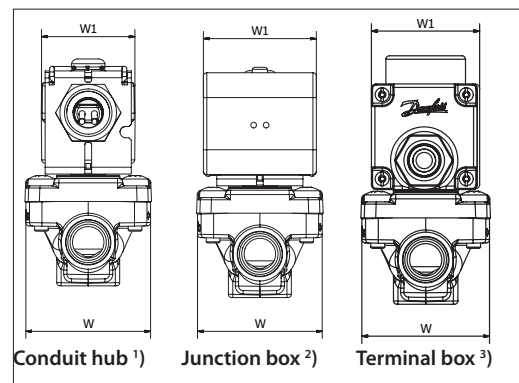

Type	Connection		Manual operation	H ₁ [in]	H ₂ [in]	H ₄ [in]	L [in]	L ₁ [in]	L ₂ [in]	L ₃ [in]	L _c [in]	W [in]	W ₁ max. [in]	Net weight without coil [lbs]
	[in]	[mm]												
EVR 15	5/8	16	Yes	0.75	3.50	2.13	6.85	3.43	0.47	0.67	-	2.20	-	1.54
	5/8	16	No	0.75	3.50	-	6.85	3.43	0.47	0.67	-	2.20	-	1.54
	7/8	22	No	0.75	3.50	-	6.85	3.43	0.67	0.67	-	2.20	-	1.54
EVR 18	7/8	22	Yes	0.75	3.50	2.13	7.05	3.52	0.67	0.67	-	2.20	-	1.54
Cable coil ¹⁾											1.93	-	1.81	-
DIN plug coil ²⁾											2.52	-	1.85	-
Terminal box coil 10 W ³⁾											2.83	-	1.85	-
Terminal box coil 12 / 20 W ³⁾											3.15	-	2.68	-

Net weight of coil (approx.)

Conduit hub: 0.72 lbs

Junction box: 0.86 lbs

Terminal box: 1.10 lbs

For 3D models, visit www.danfoss.com/products/categories/

Dimensions and weights

EVR 20 - EVR 22
Solder connection

Cable coil ¹⁾

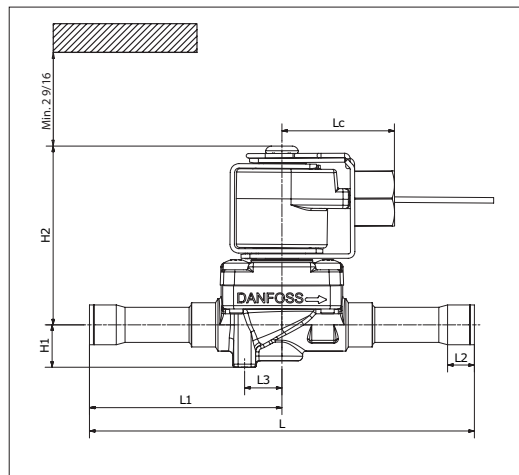

DIN plug coil ²⁾

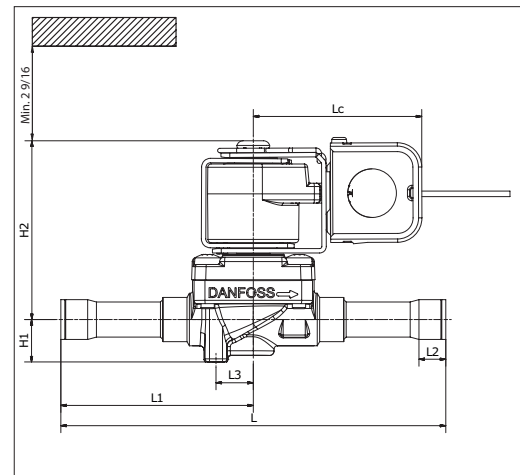

Terminal box coil ³⁾

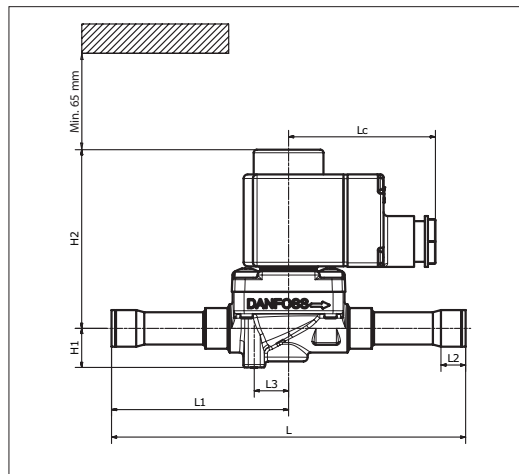

Manual stem

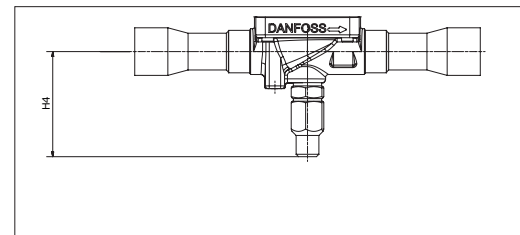

End view

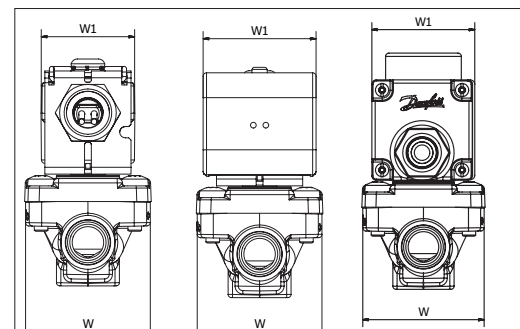

Conduit hub ¹⁾ Junction box ²⁾ Terminal box ³⁾

Type	Connection		Manual operation	H ₁ [in]	H ₂ [in]	H ₄ [in]	L [in]	L ₁ [in]	L ₂ [in]	L ₃ [in]	L _c [in]	W [in]	W ₁ max. [in]	Net weight without coil [lbs]
	[in]	[mm]												
EVR 20	7/8	22	Yes	0.75	3.66	2.20	7.48	3.74	0.67	0.79	-	2.83	-	2.78
	7/8	22	No	0.75	3.66	-	7.48	3.74	0.67	0.79	-	2.83	-	2.78
	1 1/8	28	No	0.75	3.66	-	8.54	4.27	0.79	0.79	-	2.83	-	2.89
EVR 22	1 1/8	28	Yes	0.75	3.66	2.20	8.74	4.37	0.79	0.79	-	2.83	-	2.89
	1 1/8	28	No	0.75	3.66	-	10.51	5.26	0.79	0.79	-	2.83	-	3.24
	1 3/8	35	No	0.75	3.66	-	11.50	5.75	0.98	0.79	-	2.83	-	3.24
Cable coil ¹⁾											1.93	-	1.81	-
DIN plug coil ²⁾											2.52	-	1.85	-
Terminal box coil 10 W ³⁾											2.83	-	1.85	-
Terminal box coil 12 / 20 W ³⁾											3.15	-	2.68	-

Net weight of coil (approx.)

Conduit hub: 0.72 lbs

Junction box: 0.86 lbs

Terminal box: 1.10 lbs

For 3D models, visit www.danfoss.com/products/categories/

Dimensions and weights

EVR 25
Solder connection

Conduit hub ¹⁾

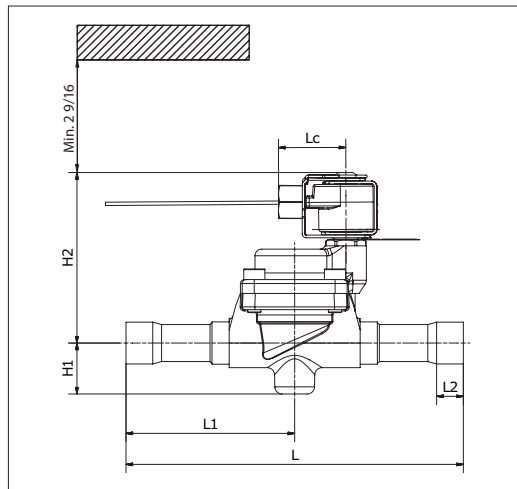

Junction box ²⁾

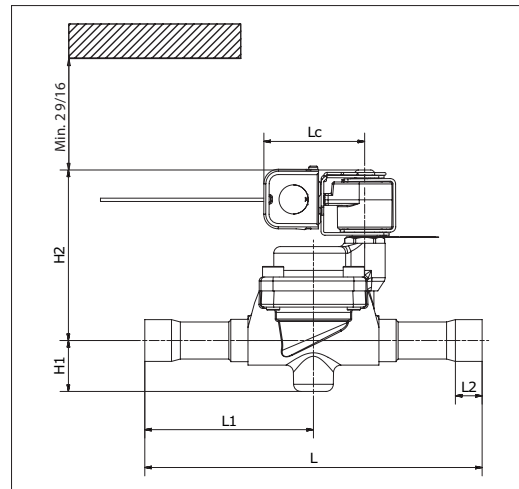

Terminal box ³⁾

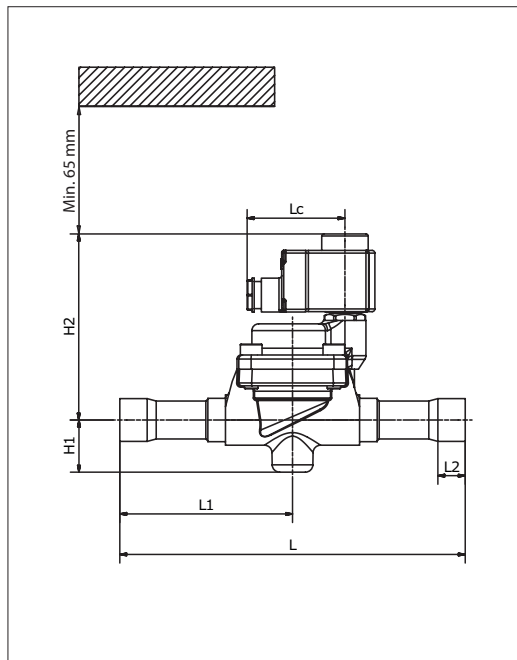

Manual stem

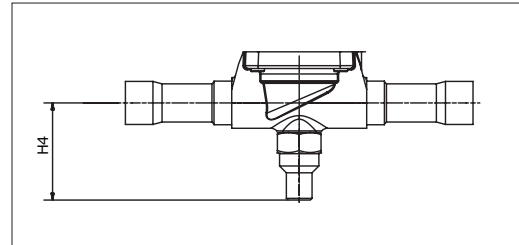

End view

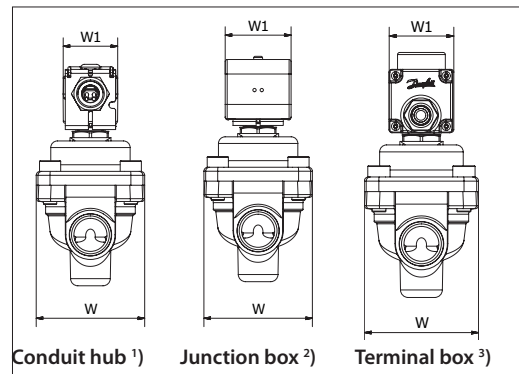

Type	Connection		Manual operation	H ₁ [in]	H ₂ [in]	H ₄ [in]	L [in]	L ₁ [in]	L ₂ [in]	L _c [in]	W [in]	W ₁ max. [in]	Net weight without coil [lbs]	
	[in]	[mm]												
EVR 25	1 1/8	28	Yes	1.54	5.43	2.80	10.04	5.02	0.79	-	3.23	-	5.89 *)	
	1 1/8	28	No	1.54	5.43	-	10.04	5.02	0.79	-	3.23	-	5.89 *)	
	1 3/8	35	Yes	1.54	5.43	2.80	11.06	5.53	0.98	-	3.23	-	6.17 *)	
	1 3/8	35	No	1.54	5.43	-	11.06	5.53	0.98	-	3.23	-	6.17 *)	
*) Manual stem: +0.13 lbs														
Cable coil ¹⁾											1.93	-	1.81	-
DIN plug coil ²⁾											2.52	-	1.85	-
Terminal box coil 10 W ³⁾											2.83	-	1.85	-
Terminal box coil 12 / 20 W ³⁾											3.15	-	2.68	-

Net weight of coil (approx.)

Conduit hub: 0.72 lbs

Junction box: 0.86 lbs

Terminal box: 1.10 lbs

For 3D models, visit www.danfoss.com/products/categories/

Dimensions and weights

EVR 32 - EVR 40
Solder connection

Conduit hub ¹⁾

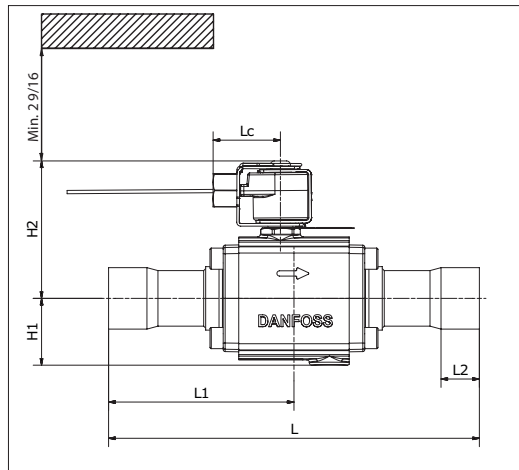

Junction box ²⁾

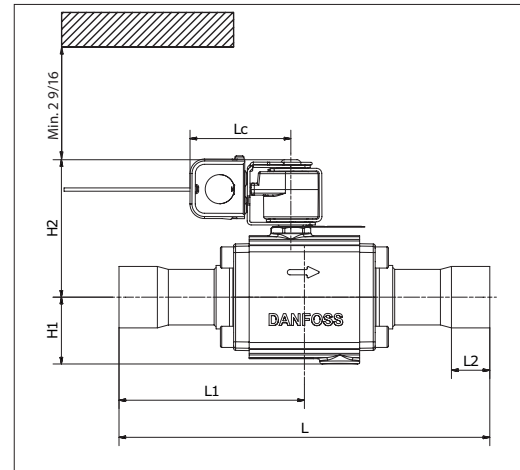

Terminal box ³⁾

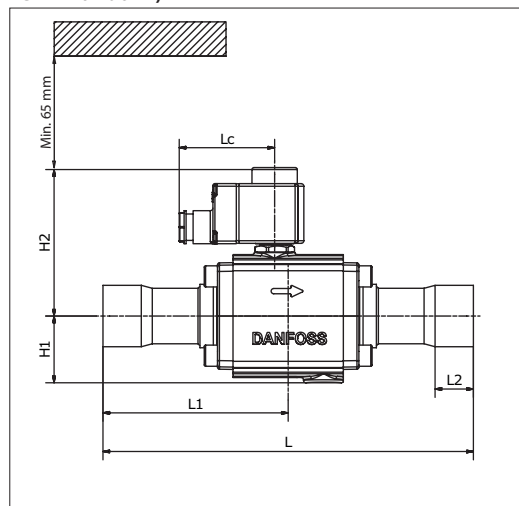

Manual stem

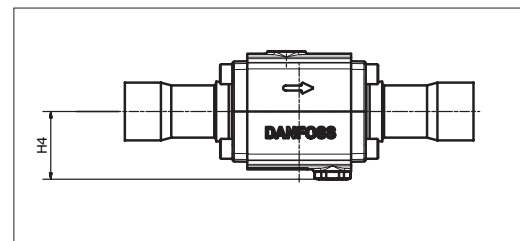

End view

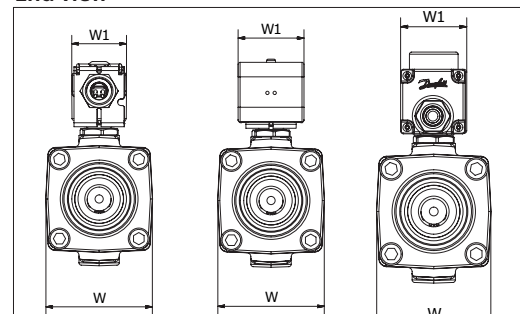

Conduit hub ¹⁾ Junction box ²⁾ Terminal box ³⁾

Type	Connection		Manual operation	H ₁ [in]	H ₂ [in]	H ₄ [in]	L [in]	L ₁ [in]	L ₂ [in]	L _c [in]	W [in]	W ₁ max. [in]	Net weight without coil [lbs]
	[in]	[mm]											
EVR 32	1 3/8	35	Yes	-	4.37	2.17	11.02	5.51	0.98	-	3.19	-	9.48
	1 3/8	35	No	2.01	4.37	-	11.02	5.51	0.98	-	3.19	-	9.48
	1 5/8	42	Yes	-	4.37	2.17	11.02	5.51	1.14	-	3.19	-	9.70
	1 5/8	42	No	2.01	4.37	-	11.02	5.51	1.14	-	3.19	-	9.70
	2 1/8	-	Yes	-	4.37	2.17	11.02	5.51	1.34	-	3.15	-	10.08
	2 1/8	-	No	2.01	4.37	-	11.02	5.51	1.34	-	3.15	-	10.08
EVR 40	1 5/8	42	Yes	-	4.37	2.17	11.02	5.51	1.14	-	3.19	-	9.70
	1 5/8	42	No	2.01	4.37	-	11.02	5.51	1.14	-	3.19	-	9.70
	2 1/8	-	Yes	-	4.37	2.17	11.02	5.51	1.34	-	3.15	-	10.08
	2 1/8	-	No	2.01	4.37	-	11.02	5.51	1.34	-	3.15	-	10.08
Cable coil ¹⁾										1.93	-	1.81	-
DIN plug coil ²⁾										2.52	-	1.85	-
Terminal box coil 10 W ³⁾										2.83	-	1.85	-
Terminal box coil 12 / 20 W ³⁾										3.15	-	2.68	-

Net weight of coil (approx.)

Conduit hub: 0.72 lbs
 Junction box: 0.86 lbs
 Terminal box: 1.10 lbs

For 3D models, visit www.danfoss.com/products/categories/

Data sheet | Solenoid valve, types EVR 2 - EVR 40 Version 2

Dimensions [mm]
and weights [kg]

EVRC 15
Solder connection

Conduit hub ¹⁾

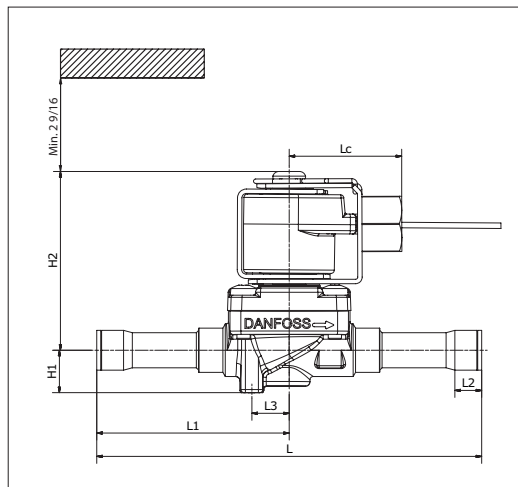

Junction box ²⁾

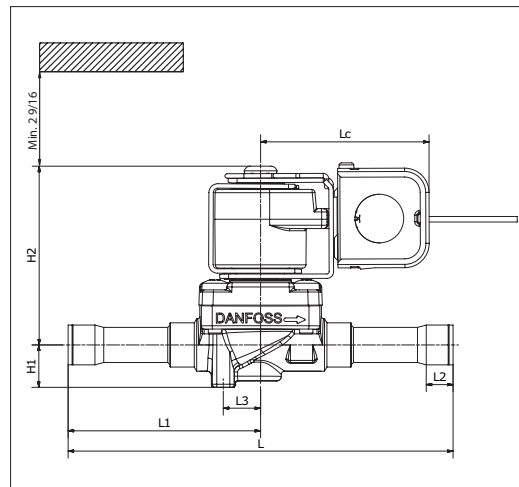

Terminal box ³⁾

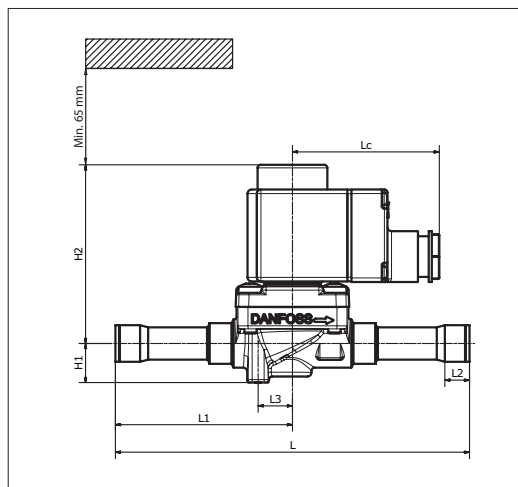

End view

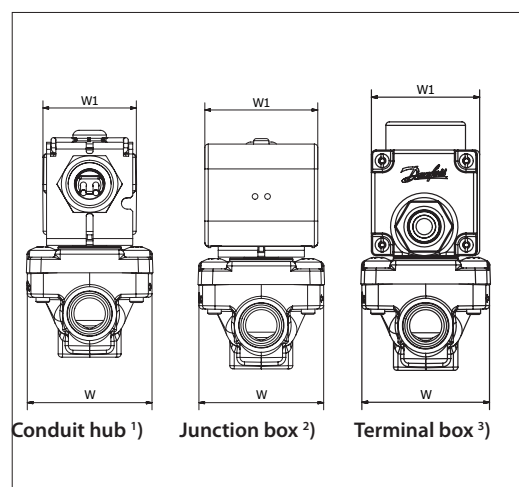

Type	Connection		Manual operation	H ₁ [in]	H ₂ [in]	L [in]	L ₁ [in]	L ₂ [in]	L ₃ [in]	L _c [in]	W [in]	W ₁ max. [in]	Net weight without coil [lbs]
	[in]	[mm]											
EVRC 15	5/8	16	No	0.75	3.50	6.85	3.43	0.47	0.67	–	2.20	–	1.54
Cable coil ¹⁾										1.93	–	1.81	–
DIN plug coil ²⁾										2.52	–	1.85	–
Terminal box coil 10 W ³⁾										2.83	–	1.85	–
Terminal box coil 12 / 20 W ³⁾										3.15	–	2.68	–

Net weight of coil (approx.)

Conduit hub: 0.72 lbs

Junction box: 0.86 lbs

Terminal box: 1.10 lbs

For 3D models, visit www.danfoss.com/products/categories/

Data sheet | Solenoid valve, types EVR 2 - EVR 40 Version 2

Dimensions and weights

EVRC 20
Solder connection

Conduit hub ¹⁾

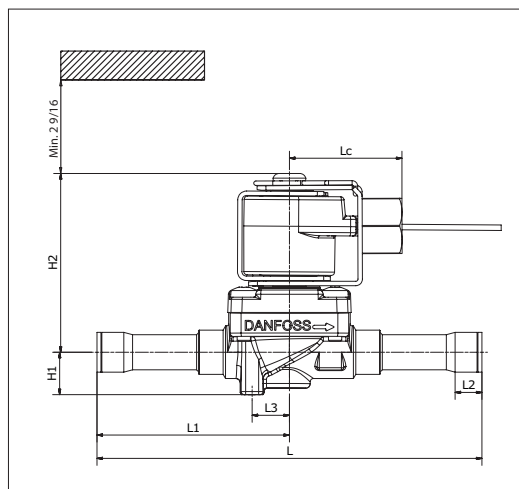

Junction box ²⁾

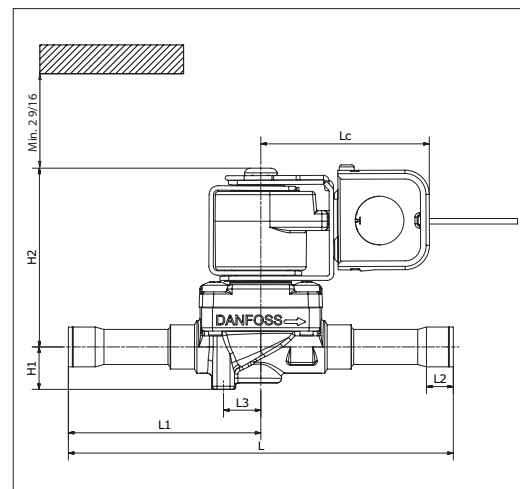

Terminal box ³⁾

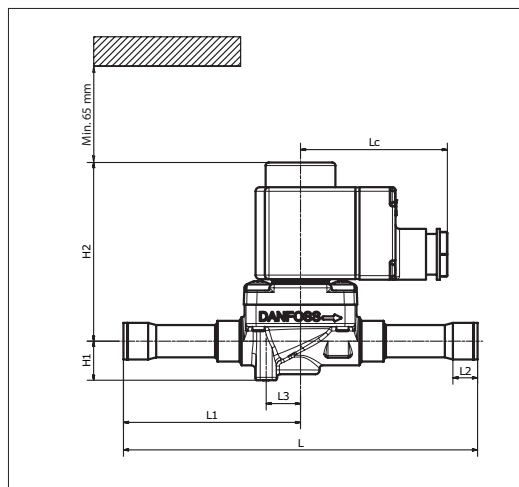

End view

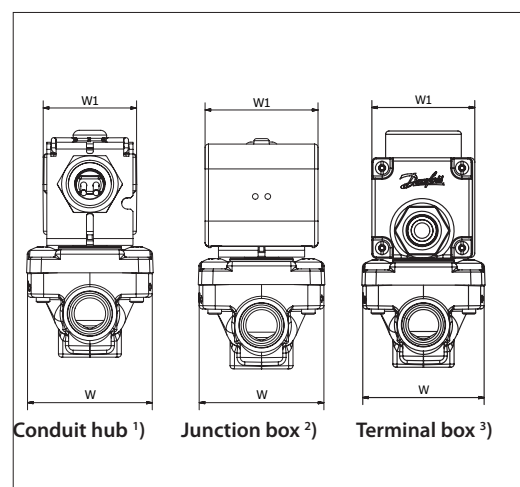

Type	Connection		Manual operation	H ₁ [in]	H ₂ [in]	L [in]	L ₁ [in]	L ₂ [in]	L ₃ [in]	L _c [in]	W [in]	W ₁ max. [in]	Net weight without coil [lbs]
	[in]	[mm]											
EVRC 20	7/8	22	No	0.75	3.66	7.48	3.74	0.67	0.79	–	2.83	–	2.78
Cable coil ¹⁾										1.93	–	1.81	–
DIN plug coil ²⁾										2.52	–	1.85	–
Terminal box coil 10 W ³⁾										2.83	–	1.85	–
Terminal box coil 12 / 20 W ³⁾										3.15	–	2.68	–

Net weight of coil (approx.)

Conduit hub: 0.72 lbs

Junction box: 0.86 lbs

Terminal box: 1.10 lbs

For 3D models, visit www.danfoss.com/products/categories/

Dimensions and weights

EVR 2 - EVR 3
Flare connection

Conduit hub ¹⁾

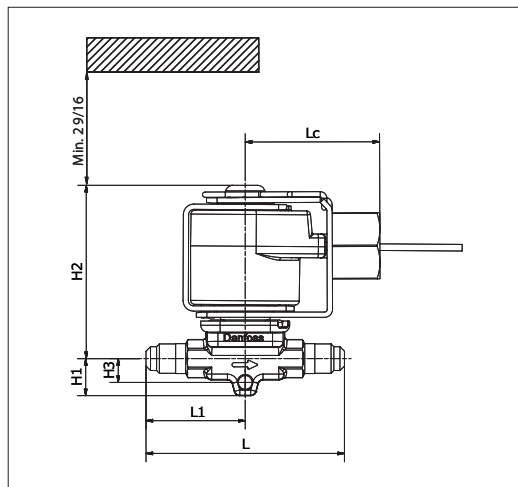

Junction box ²⁾

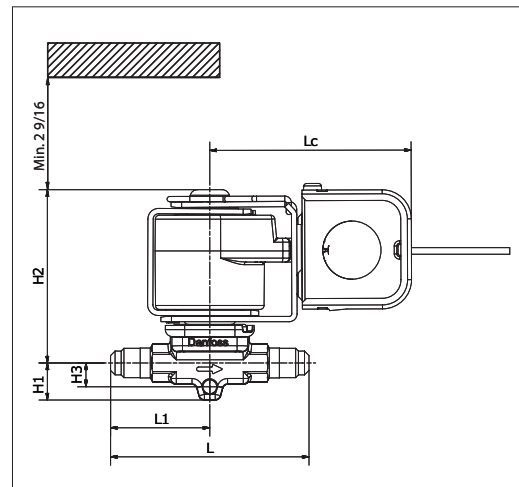

Terminal box ³⁾

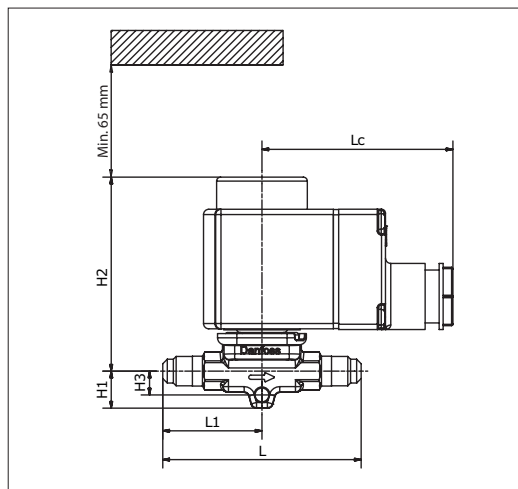

End view

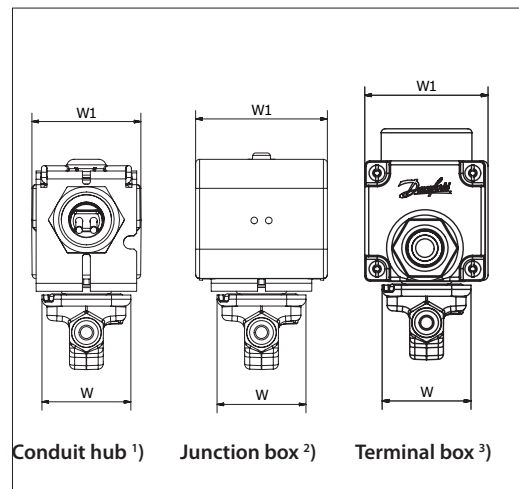

Type	Connection		H ₁ [in]	H ₂ [in]	H ₃ [in]	L [in]	L ₁ [in]	L _c [in]	W [in]	W ₁ max. [in]	Net weight without coil [lbs]
	[in]	[mm]									
EVR 2	1/4	6	0.55	2.87	0.35	2.95	1.48	–	1.34	–	0.40
EVR 3	1/4	6	0.55	2.87	0.35	2.95	1.48	–	1.34	–	0.40
	3/8	10	0.55	2.87	0.35	2.95	1.48	–	1.34	–	0.40
Cable coil ¹⁾								1.93	–	1.81	–
DIN plug coil ²⁾								2.52	–	1.85	–
Terminal box coil 10 W ³⁾								2.83	–	1.85	–
Terminal box coil 12 / 20 W ³⁾								3.15	–	2.68	–

Net weight of coil (approx.)

Conduit hub: 0.72 lbs

Junction box: 0.86 lbs

Terminal box: 1.10 lbs

For 3D models, visit www.danfoss.com/products/categories/

Dimensions and weights

EVR 6
Flare connection

Conduit hub ¹⁾

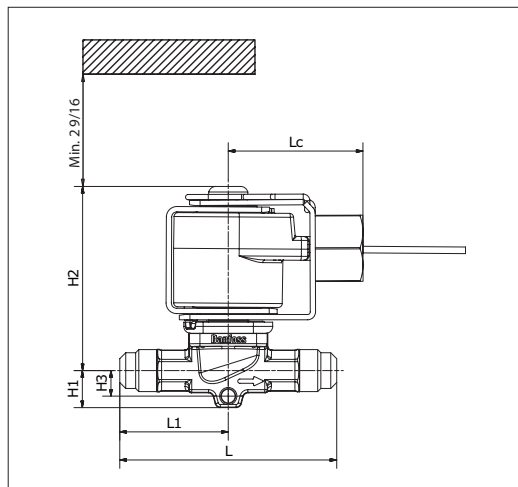

Junction box ²⁾

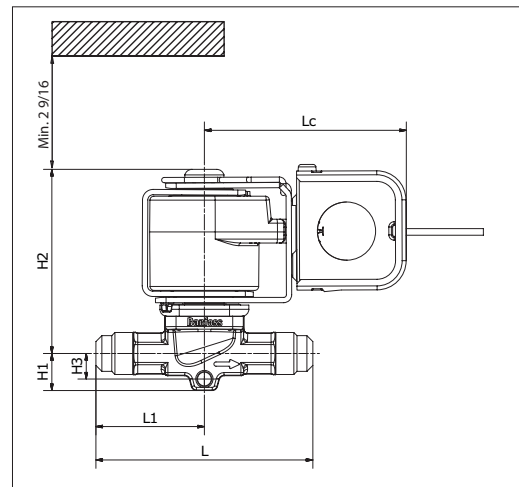

Terminal box ³⁾

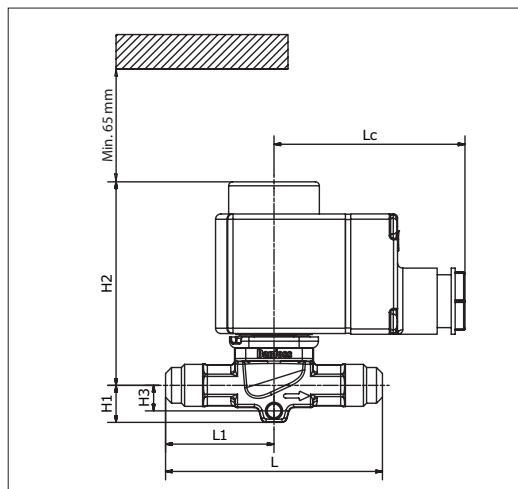

End view

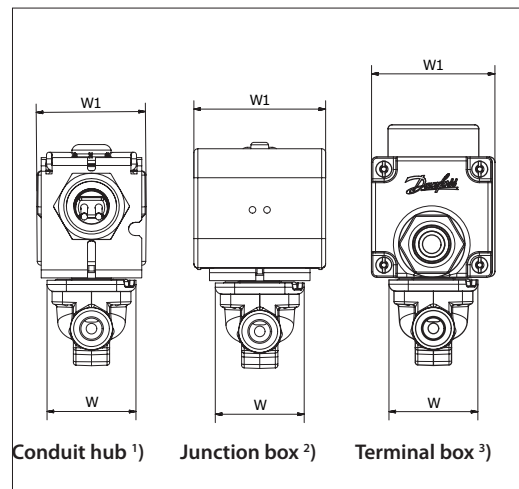

Type	Connection		H ₁ [in]	H ₂ [in]	H ₃ [in]	L [in]	L ₁ [in]	L _c [in]	W [in]	W ₁ max. [in]	Net weight without coil [lbs]
	[in]	[mm]									
EVR 6	3/8	10	0.55	3.03	0.39	3.23	1.61	–	1.34	–	0.46
	1/2	12	0.55	3.03	0.39	3.46	1.73	–	1.34	–	0.49
Cable coil ¹⁾								1.93	–	1.81	–
DIN plug coil ²⁾								2.52	–	1.85	–
Terminal box coil 10 W ³⁾								2.83	–	1.85	–
Terminal box coil 12 / 20 W ³⁾								3.15	–	2.68	–

Net weight of coil (approx.)

Conduit hub: 0.72 lbs

Junction box: 0.86 lbs

Terminal box: 1.10 lbs

For 3D models, visit www.danfoss.com/products/categories/

Dimensions and weights

EVR 10
Flare connection

Conduit hub ¹⁾

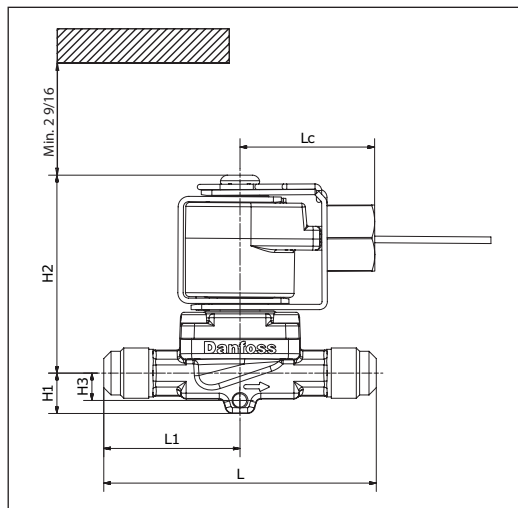

Junction box ²⁾

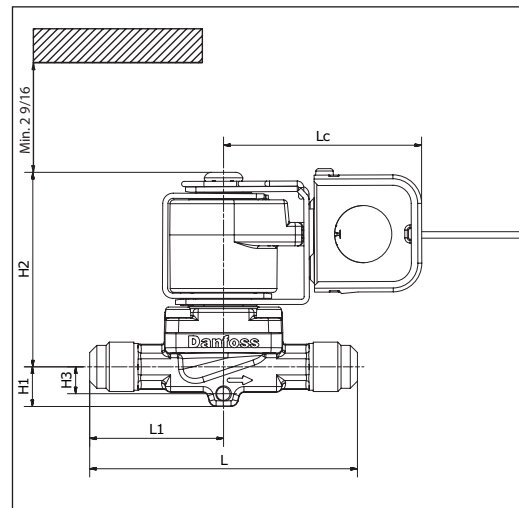

Terminal box ³⁾

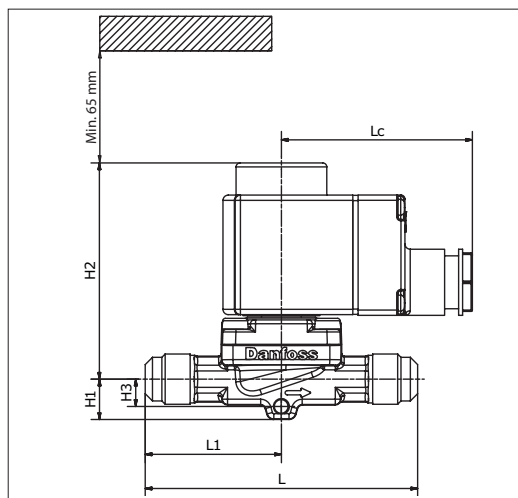

End view

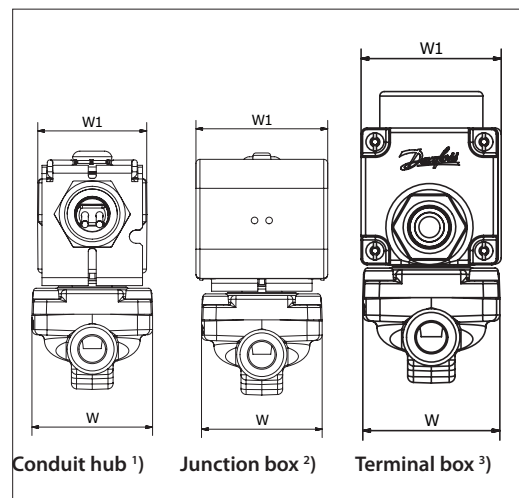

Type	Connection		H ₁ [in]	H ₂ [in]	H ₃ [in]	L [in]	L ₁ [in]	L _c [in]	W [in]	W ₁ max. [in]	Net weight without coil [lbs]	
	[in]	[mm]										
EVR 10	1/2	12	0.59	3.23	0.39	4.06	2.03	–	1.81	–	0.97	
	5/8	16	0.59	3.23	0.39	4.33	2.17	–	1.81	–	0.99	
Cable coil ¹⁾									1.93	–	1.81	–
DIN plug coil ²⁾									2.52	–	1.85	–
Terminal box coil 10 W ³⁾									2.83	–	1.85	–
Terminal box coil 12 / 20 W ³⁾									3.15	–	2.68	–

Net weight of coil (approx.)

Conduit hub: 0.72 lbs

Junction box: 0.86 lbs

Terminal box: 1.10 lbs

For 3D models, visit www.danfoss.com/products/categories/

Dimensions and weights

EVR 15
Flare connection

Conduit hub ¹⁾

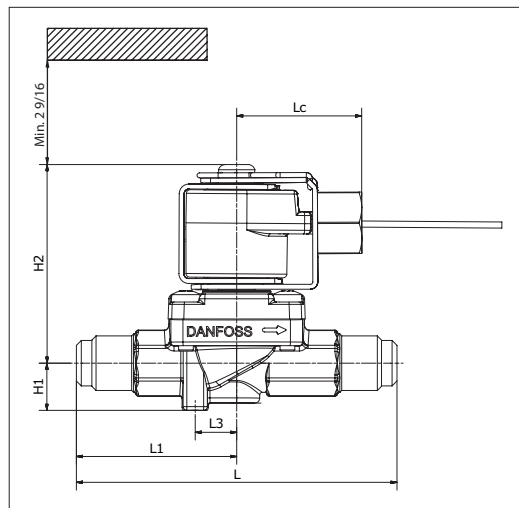

Junction box ²⁾

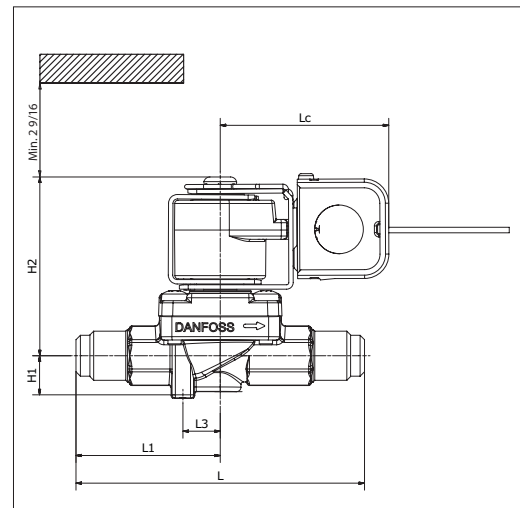

Terminal box ³⁾

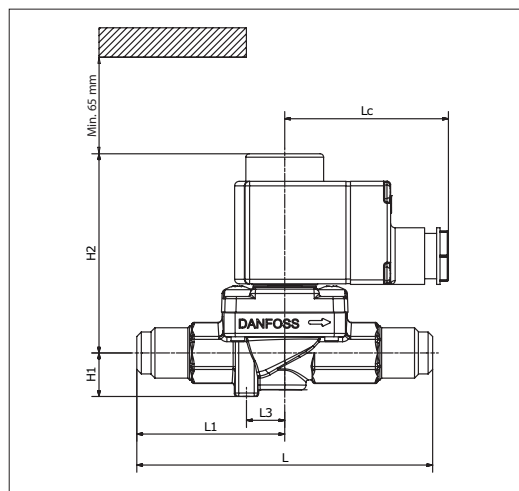

Manual stem

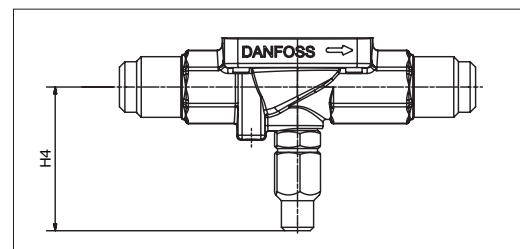

End view

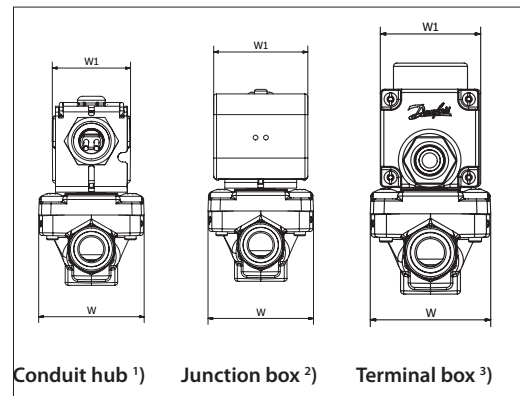

Type	Connection		Manual operation	H ₁ [in]	H ₂ [in]	H ₄ [in]	L [in]	L ₁ [in]	L ₃ [in]	L _c [in]	W [in]	W ₁ max. [in]	Net weight without coil [lbs]
	[in]	[mm]											
EVR 15	5/8	16	Yes	0.75	3.50	2.09	5.16	2.58	0.67	–	2.20	–	1.72
	5/8	16	No	0.75	3.50	–	5.16	2.58	0.67	–	2.20	–	1.72
Cable coil ¹⁾										1.93	–	1.81	–
DIN plug coil ²⁾										2.52	–	1.85	–
Terminal box coil 10 W ³⁾										2.83	–	1.85	–
Terminal box coil 12 / 20 W ³⁾										3.15	–	2.68	–

Net weight of coil (approx.)

Conduit hub: 0.72 lbs

Junction box: 0.86 lbs

Terminal box: 1.10 lbs

For 3D models, visit www.danfoss.com/products/categories/

Dimensions and weights

EVR 15
Flange connection

Conduit hub ¹⁾

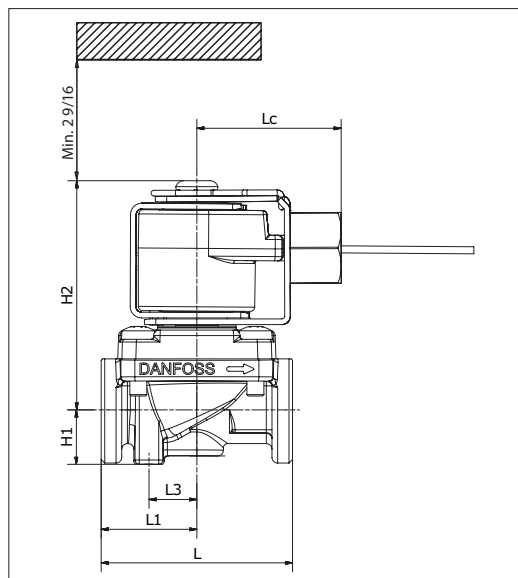

Junction box ²⁾

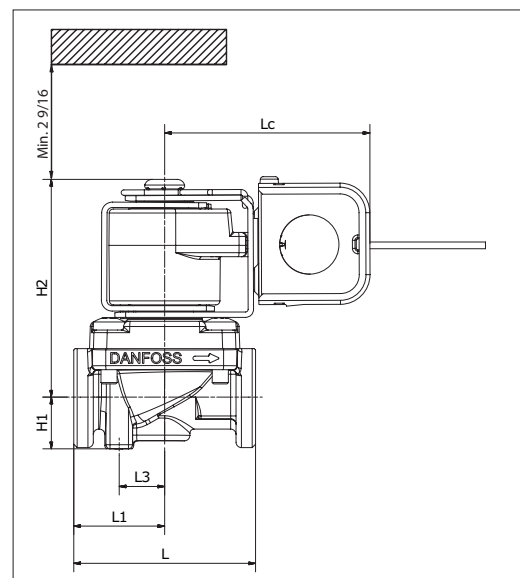

Terminal box ³⁾

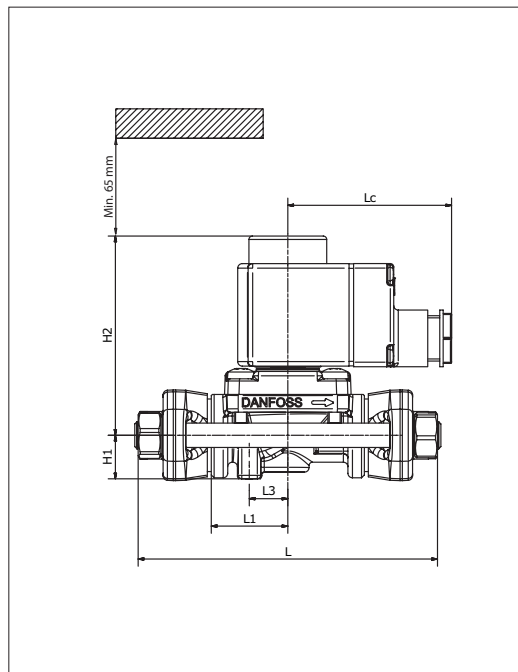

Manual stem

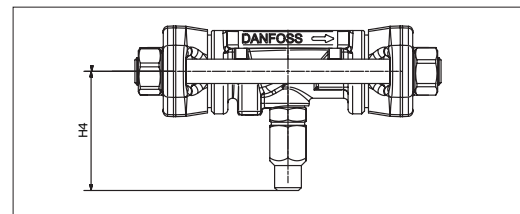

End view

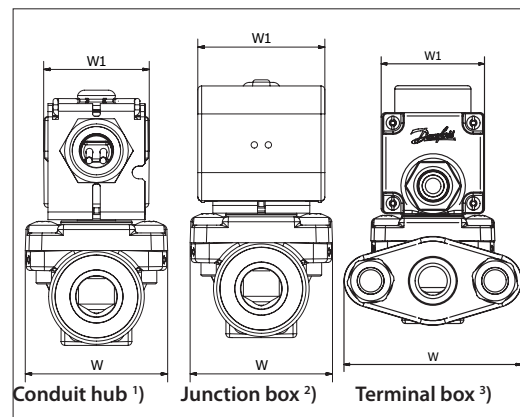

Type	Manual operation	H ₁ [in]	H ₂ [in]	H ₄ [in]	L [in]	L ₁ [in]	L ₃ [in]	L _c [in]	W [in]	W ₁ max. [in]	Net weight without coil [lbs]
EVR 15	Yes	0.75	3.50	2.09	4.96	1.33	0.67	–	3.15	–	1.41
	No	0.75	3.50	–	4.96	1.33	0.67	–	3.15	–	1.41
Cable coil ¹⁾								1.93	–	1.81	–
DIN plug coil ²⁾								2.52	–	1.85	–
Terminal box coil 10 W ³⁾								2.83	–	1.85	–
Terminal box coil 12 / 20 W ³⁾								3.15	–	2.68	–

Net weight of coil (approx.)

Conduit hub: 0.72 lbs

Junction box: 0.86 lbs

Terminal box: 1.10 lbs

For 3D models, visit www.danfoss.com/products/categories/

Dimensions and weights

EVR 20
Flange connection

Conduit hub ¹⁾

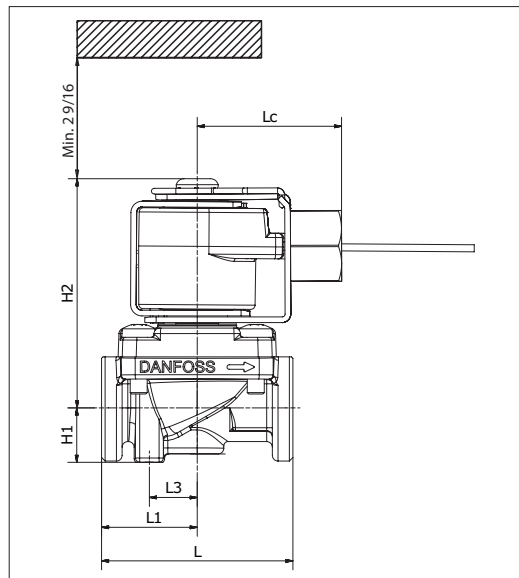

Junction box ²⁾

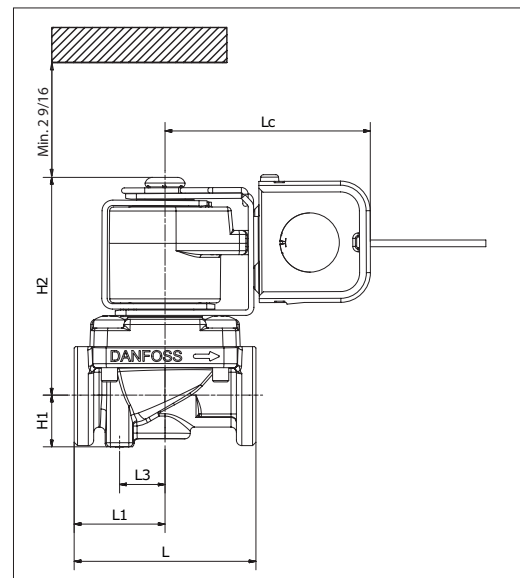

Terminal box ³⁾

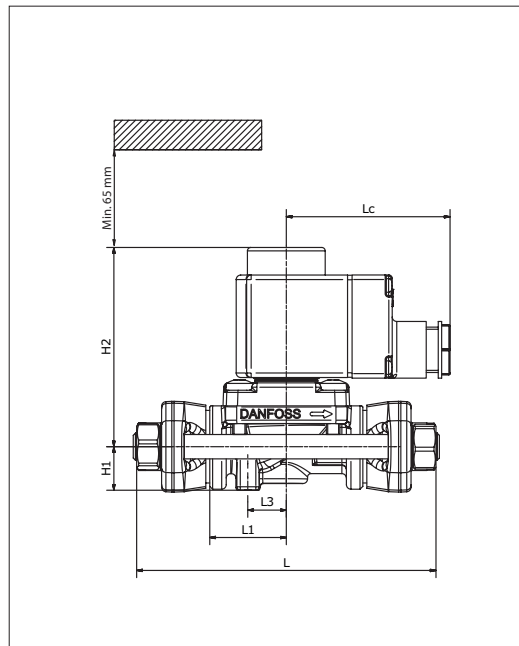

Manual stem

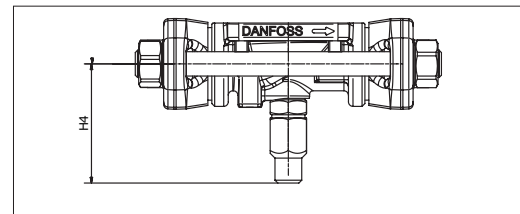

End view

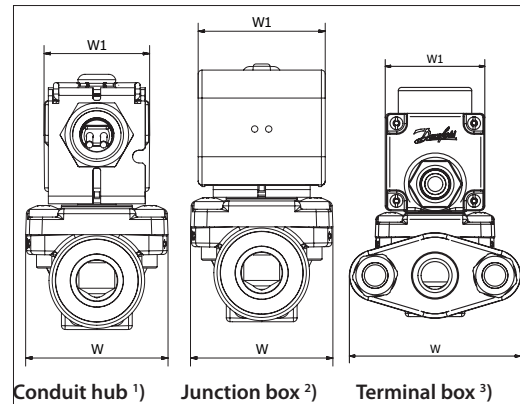

Type	Manual operation	H ₁ [in]	H ₂ [in]	H ₄ [in]	L [in]	L ₁ [in]	L ₃ [in]	L _c [in]	W [in]	W ₁ max. [in]	Net weight without coil [lbs]
EVR 20	Yes	0.75	3.66	2.20	6.14	1.67	0.79	–	3.78	–	2.65
	No	0.75	3.66	–	6.14	1.67	0.79	–	3.78	–	2.65
Cable coil ¹⁾								1.93	–	1.81	–
DIN plug coil ²⁾								2.52	–	1.85	–
Terminal box coil 10 W ³⁾								2.83	–	1.85	–
Terminal box coil 12 / 20 W ³⁾								3.15	–	2.68	–

Net weight of coil (approx.)

Conduit hub: 0.72 lbs

Junction box: 0.86 lbs

Terminal box: 1.10 lbs

For 3D models, visit www.danfoss.com/products/categories/

Data sheet | Solenoid valve, types EVR 2 - EVR 40 Version 2

Extended capacity
Liquid

Type	Liquid capacity Q _e [TR] at pressure drop across valve Δp [psi]						
	1	2	3	4	5	6	7
R22/R407C							
EVR 2	0.55	0.77	0.95	1.09	1.22	1.34	1.44
EVR 3	0.98	1.39	1.70	1.97	2.20	2.41	2.60
EVR 4	2.48	3.50	4.29	4.95	5.54	6.06	6.55
EVR 6	3.24	4.58	5.61	6.48	7.24	7.94	8.57
EVR 8	3.86	5.46	6.68	7.72	8.63	9.45	10.21
EVR 10	6.81	9.63	11.79	13.61	15.22	16.67	18.01
EVR 15	10.48	14.83	18.16	20.97	23.44	25.68	27.74
EVR 18	13.72	19.41	23.77	27.45	30.69	33.62	36.31
EVR 20	21.77	30.79	37.71	43.54	48.68	53.32	57.60
EVR 22	24.83	35.11	43.00	49.65	55.52	60.81	65.69
EVR 25	0.27	33.44	61.73	71.28	79.69	87.30	94.29
EVR 32	0.46	57.13	105.49	121.81	136.18	149.18	161.13
EVR 40	0.65	82.62	152.59	176.19	196.99	215.79	233.08
R134a							
EVR 2	0.51	0.72	0.88	1.02	1.14	1.25	1.35
EVR 3	0.92	1.30	1.59	1.84	2.05	2.25	2.43
EVR 4	2.31	3.27	4.00	4.62	5.17	5.66	6.12
EVR 6	3.03	4.28	5.24	6.05	6.77	7.41	8.00
EVR 8	3.60	5.10	6.24	7.21	8.06	8.83	9.53
EVR 10	6.36	8.99	11.01	12.71	14.21	15.57	16.82
EVR 15	9.79	13.85	16.96	19.58	21.89	23.98	25.90
EVR 18	12.82	18.12	22.20	25.63	28.66	31.39	33.91
EVR 20	20.33	28.75	35.21	40.66	45.46	49.79	53.78
EVR 22	23.18	32.79	40.16	46.37	51.84	56.79	61.34
EVR 25	0.25	31.22	57.64	66.56	74.42	81.52	88.05
EVR 32	0.43	53.35	98.50	113.74	127.17	139.31	150.47
EVR 40	0.61	77.15	142.49	164.53	183.95	201.51	217.65

Capacities are based on:
Liquid temperature: 100.0 °F
Subcooling: 10.0 °F
Evaporating temperature:
40.0 °F
Superheat: 0 °F

Metric conversions
1 psi = 0.07 bar
 $\frac{5}{9}(t_1 \text{ °F} - 32) = t_2 \text{ °C}$
1 TR = 3.5 kW

Correction factors

When sizing valves, the plant capacity must be multiplied by a correction factor depending on liquid temperature t_l ahead of valve/evaporator.

When the corrected capacity is known, the selection can be made from the table.

Correction factors based on liquid temperature t_l

t_l [°F]	80	90	100	110	120
Factor	1.10	1.05	1.00	0.95	0.90

Data sheet | Solenoid valve, types EVR 2 - EVR 40 Version 2
**Extended capacity
Liquid**
(continued)

Type	Liquid capacity Q _e [TR] at pressure drop across valve Δp [psi]						
	1	2	3	4	5	6	7
R404A/R507							
EVR 2	0.36	0.51	0.62	0.72	0.80	0.88	0.95
EVR 3	0.65	0.91	1.12	1.29	1.45	1.58	1.71
EVR 4	1.63	2.30	2.82	3.26	3.64	3.99	4.31
EVR 6	2.13	3.01	3.69	4.26	4.77	5.22	5.64
EVR 8	2.54	3.59	4.40	5.08	5.68	6.22	6.72
EVR 10	4.48	6.33	7.76	8.96	10.01	10.97	11.85
EVR 15	6.90	9.75	11.94	13.79	15.42	16.89	18.25
EVR 18	9.03	12.77	15.64	18.05	20.19	22.11	23.88
EVR 20	14.32	20.25	24.80	28.64	32.02	35.07	37.88
EVR 22	16.33	23.09	28.29	32.66	36.52	40.00	43.21
EVR 25	0.18	21.99	40.60	46.88	52.42	57.42	62.02
EVR 32	0.30	37.58	69.39	80.12	89.58	98.13	105.99
EVR 40	0.43	54.34	100.37	115.89	129.57	141.94	153.31
R410A							
EVR 2	0.52	0.73	0.89	1.03	1.15	1.26	1.36
EVR 3	0.93	1.31	1.61	1.86	2.08	2.27	2.46
EVR 4	2.34	3.31	4.05	4.68	5.23	5.73	6.19
EVR 6	3.06	4.33	5.30	6.12	6.84	7.50	8.10
EVR 8	3.64	5.15	6.31	7.29	8.15	8.93	9.64
EVR 10	6.43	9.09	11.14	12.86	14.38	15.75	17.01
EVR 15	9.90	14.00	17.15	19.80	22.14	24.25	26.20
EVR 18	12.96	18.33	22.45	25.92	28.98	31.75	34.29
EVR 20	20.56	29.08	35.61	41.12	45.97	50.36	54.40
EVR 22	23.45	33.16	40.61	46.90	52.43	57.44	62.04
EVR 25	0.25	31.58	58.30	67.32	75.27	82.45	89.06
EVR 32	0.43	53.96	99.63	115.04	128.62	140.90	152.19
EVR 40	0.62	78.03	144.11	166.41	186.05	203.81	220.14

Capacities are based on:
Liquid temperature: 100.0 °F
Subcooling: 10.0 °F
Evaporating temperature:
40.0 °F
Superheat: 0 °F

Metric conversions
1 psi = 0.07 bar
 $\frac{5}{9} (t_1 \text{ °F} - 32) = t_2 \text{ °C}$
1 TR = 3.5 kW

Correction factors

When sizing valves, the plant capacity must be multiplied by a correction factor depending on liquid temperature t_l ahead of valve/evaporator.

When the corrected capacity is known, the selection can be made from the table.

Correction factors based on liquid temperature t_l

t_l [°F]	80	90	100	110	120
Factor	1.10	1.05	1.00	0.95	0.90

Data sheet | Solenoid valve, types EVR 2 - EVR 40 Version 2
**Extended capacity
Liquid**
(continued)

Type	Liquid capacity Q _e [TR] at pressure drop across valve Δp [psi]						
	1	2	3	4	5	6	7
R32							
EVR 2	0.74	1.05	1.29	1.49	1.67	1.82	1.97
EVR 3	1.34	1.90	2.32	2.68	3.00	3.28	3.55
EVR 4	3.38	4.78	5.85	6.75	7.55	8.27	8.93
EVR 6	4.42	6.25	7.65	8.84	9.88	10.83	11.69
EVR 8	5.26	7.44	9.12	10.53	11.77	12.89	13.93
EVR 10	9.29	13.13	16.08	18.57	20.76	22.74	24.57
EVR 15	14.30	20.22	24.77	28.60	31.98	35.03	37.84
EVR 18	18.72	26.47	32.42	37.44	41.86	45.85	49.53
EVR 20	29.69	41.99	51.43	59.39	66.40	72.74	78.56
EVR 22	33.87	47.89	58.66	67.73	75.72	82.95	89.60
R290							
EVR 2	0.61	0.87	1.06	1.23	1.37	1.50	1.62
EVR 3	1.11	1.56	1.91	2.21	2.47	2.71	2.92
EVR 4	2.78	3.94	4.82	5.57	6.22	6.82	7.36
EVR 6	3.64	5.15	6.31	7.29	8.15	8.92	9.64
EVR 8	4.34	6.14	7.52	8.68	9.70	10.63	11.48
EVR 10	7.65	10.83	13.26	15.31	17.12	18.75	20.25
EVR 15	11.79	16.67	20.42	23.58	26.36	28.88	31.19
EVR 18	15.43	21.82	26.73	30.87	34.51	37.80	40.83
EVR 20	24.48	34.62	42.40	48.96	54.74	59.96	64.77
EVR 22	27.92	39.48	48.36	55.84	62.43	68.38	73.86
R600a							
EVR 2	0.63	0.90	1.10	1.27	1.42	1.55	1.68
EVR 3	1.14	1.61	1.98	2.28	2.55	2.80	3.02
EVR 4	2.87	4.06	4.98	5.75	6.43	7.04	7.60
EVR 6	3.76	5.32	6.52	7.52	8.41	9.21	9.95
EVR 8	4.48	6.34	7.76	8.96	10.02	10.97	11.85
EVR 10	7.90	11.18	13.69	15.81	17.67	19.36	20.91
EVR 15	12.17	17.21	21.08	24.35	27.22	29.82	32.21
EVR 18	15.93	22.53	27.60	31.87	35.63	39.03	42.16
EVR 20	25.27	35.74	43.78	50.55	56.52	61.91	66.87
EVR 22	28.83	40.77	49.93	57.65	64.46	70.61	76.26

Capacities are based on:
Liquid temperature t_l = 100 °F
Evaporating temperature t_e = 40 °F
Superheat temperature (t_e + 10 °F) = 50 °F

Metric conversions
1 psi = 0.07 bar
 $\frac{5}{9}(t_1 \text{ °F} - 32) = t_2 \text{ °C}$
1 TR = 3.5 kW

Correction factors

When sizing valves, the plant capacity must be multiplied by a correction factor depending on liquid temperature t_l ahead of valve/evaporator.

When the corrected capacity is known, the selection can be made from the table.

Correction factors based on liquid temperature t_l

t _l [°F]	80	90	100	110	120
Factor	1.10	1.05	1.00	0.95	0.90

Data sheet | Solenoid valve, types EVR 2 - EVR 40 Version 2
**Extended capacity
Suction**

Type	Pressure drop Δp [psi]	Suction vapour capacity Qe [TR] at evaporating temperature te [°F]							
		-40	-20	0	10	20	30	40	50
R22/R407C									
EVR 2	1	0.03	0.04	0.05	0.06	0.06	0.07	0.08	0.09
	2	0.04	0.05	0.07	0.08	0.09	0.10	0.11	0.12
	3	0.05	0.06	0.08	0.10	0.11	0.12	0.13	0.15
EVR 3	1	0.05	0.07	0.09	0.10	0.11	0.13	0.14	0.15
	2	0.07	0.10	0.13	0.14	0.16	0.18	0.20	0.22
	3	0.09	0.12	0.15	0.17	0.19	0.22	0.24	0.26
EVR 4	1	0.13	0.18	0.23	0.26	0.29	0.32	0.35	0.39
	2	0.18	0.25	0.32	0.36	0.40	0.45	0.50	0.55
	3	0.21	0.29	0.38	0.43	0.49	0.54	0.60	0.66
EVR 6	1	0.18	0.23	0.30	0.34	0.38	0.42	0.46	0.51
	2	0.24	0.32	0.42	0.47	0.53	0.59	0.65	0.72
	3	0.28	0.38	0.50	0.57	0.64	0.71	0.79	0.87
EVR 8	1	0.21	0.28	0.36	0.40	0.45	0.50	0.55	0.61
	2	0.29	0.38	0.50	0.56	0.63	0.70	0.77	0.85
	3	0.33	0.46	0.60	0.68	0.76	0.85	0.94	1.04
EVR 10	1	0.37	0.49	0.63	0.71	0.79	0.88	0.97	1.07
	2	0.50	0.68	0.88	0.99	1.11	1.23	1.36	1.50
	3	0.59	0.81	1.06	1.19	1.34	1.49	1.66	1.83
EVR 15	1	0.57	0.76	0.97	1.09	1.22	1.35	1.49	1.65
	2	0.77	1.04	1.35	1.52	1.70	1.89	2.10	2.31
	3	0.91	1.24	1.63	1.84	2.06	2.30	2.55	2.82
EVR 18	1	0.75	0.99	1.27	1.43	1.59	1.77	1.96	2.15
	2	1.01	1.37	1.77	1.99	2.23	2.48	2.75	3.03
	3	1.19	1.63	2.13	2.41	2.70	3.01	3.34	3.69

The table values refer to the evaporator capacity and are given as a function of evaporating temperature t_e and pressure drop Δp across valve.

Capacities are based on:
Liquid temperature $t_l = 100$ °F
Subcooling = 0 °F
Superheat = 7 °F

Metric conversions
1 psi = 0.07 bar
 $\frac{5}{9}(t_1 \text{ °F} - 32) = t_2 \text{ °C}$
1 TR = 3.5 kW

Correction factors

When liquid temperature t_l ahead of the expansion valve is other than 100 °F, adjust the table capacities by multiplying them by the appropriate correction factor found in the following table.

Correction factors based on liquid temperature t_l

t_l [°F]	80	90	100	110	120
Factor	1.10	1.05	1.00	0.95	0.90

Data sheet | Solenoid valve, types EVR 2 - EVR 40 Version 2

Extended capacity Suction
(continued)

Type	Pressure drop Δp [psi]	Suction vapour capacity Qe [TR] at evaporating temperature t_e [°F]							
		-40	-20	0	10	20	30	40	50
R22/R407C (continued)									
EVR 20	1	1.19	1.57	2.02	2.26	2.53	2.81	3.10	3.42
	2	1.61	2.17	2.81	3.16	3.53	3.93	4.36	4.80
	3	1.89	2.58	3.38	3.82	4.28	4.77	5.30	5.85
EVR 22	1	1.35	1.79	2.30	2.58	2.88	3.20	3.54	3.90
	2	1.83	2.47	3.20	3.60	4.03	4.49	4.97	5.48
	3	2.15	2.95	3.86	4.35	4.88	5.45	6.04	6.67
EVR 25	3	3.09	4.23	5.53	6.25	7.01	7.82	8.67	9.57
EVR 32	3	5.27	7.23	9.46	10.68	11.98	13.36	14.82	16.36
EVR 40	3	7.63	10.46	13.68	15.45	17.33	19.32	21.43	23.66

The table values refer to the evaporator capacity and are given as a function of evaporating temperature t_e and pressure drop Δp across valve.

Capacities are based on:
Liquid temperature $t_l = 100$ °F
Subcooling = 0 °F
Superheat = 7 °F

Metric conversions
1 psi = 0.07 bar
 $\frac{5}{9} (t_1 \text{ °F} - 32) = t_2 \text{ °C}$
1 TR = 3.5 kW

Correction factors

When liquid temperature t_l ahead of the expansion valve is other than 100 °F, adjust the table capacities by multiplying them by the appropriate correction factor found in the following table.

Correction factors based on liquid temperature t_l

t_l [°F]	80	90	100	110	120
Factor	1.10	1.05	1.00	0.95	0.90

Data sheet | Solenoid valve, types EVR 2 - EVR 40 Version 2
**Extended capacity
Suction**
(continued)

Type	Pressure drop Δp [psi]	Suction vapour capacity Q_e [TR] at evaporating temperature t_e [°F]							
		-40	-20	0	10	20	30	40	50
R134a									
EVR 2	1	0.02	0.03	0.04	0.04	0.05	0.05	0.06	0.07
	2	0.02	0.03	0.05	0.06	0.06	0.07	0.08	0.09
	3	0.03	0.04	0.06	0.07	0.08	0.09	0.10	0.11
EVR 3	1	0.03	0.05	0.06	0.07	0.08	0.09	0.11	0.12
	2	0.04	0.06	0.09	0.10	0.12	0.13	0.15	0.17
	3	0.05	0.07	0.10	0.12	0.14	0.16	0.18	0.20
EVR 4	1	0.08	0.12	0.16	0.18	0.21	0.24	0.27	0.30
	2	0.11	0.16	0.22	0.25	0.29	0.33	0.38	0.42
	3	0.12	0.18	0.26	0.30	0.35	0.40	0.45	0.51
EVR 6	1	0.11	0.15	0.21	0.24	0.28	0.31	0.35	0.40
	2	0.14	0.21	0.29	0.33	0.38	0.44	0.49	0.55
	3	0.15	0.24	0.34	0.40	0.46	0.52	0.60	0.67
EVR 8	1	0.13	0.18	0.25	0.29	0.33	0.37	0.42	0.47
	2	0.16	0.25	0.34	0.40	0.45	0.52	0.59	0.66
	3	0.18	0.28	0.40	0.47	0.55	0.62	0.71	0.80
EVR 10	1	0.23	0.32	0.44	0.51	0.58	0.66	0.74	0.83
	2	0.29	0.43	0.60	0.70	0.80	0.91	1.04	1.17
	3	0.32	0.50	0.71	0.83	0.96	1.10	1.25	1.41
EVR 15	1	0.35	0.50	0.68	0.78	0.89	1.01	1.14	1.28
	2	0.45	0.67	0.93	1.08	1.24	1.41	1.59	1.79
	3	0.49	0.77	1.10	1.28	1.48	1.70	1.93	2.17
EVR 18	1	0.46	0.65	0.89	1.02	1.17	1.32	1.50	1.68
	2	0.58	0.87	1.22	1.41	1.62	1.84	2.09	2.35
	3	0.64	1.01	1.44	1.68	1.94	2.22	2.52	2.85

The table values refer to the evaporator capacity and are given as a function of evaporating temperature t_e and pressure drop Δp across valve.

Capacities are based on:
Liquid temperature $t_l = 100$ °F
Subcooling = 0 °F
Superheat = 7 °F

Metric conversions
1 psi = 0.07 bar
 $\frac{5}{9}(t_1 - 32) = t_2$ °C
1 TR = 3.5 kW

Correction factors

When liquid temperature t_l ahead of the expansion valve is other than 100 °F, adjust the table capacities by multiplying them by the appropriate correction factor found in the following table.

Correction factors based on liquid temperature t_l

t_l [°F]	80	90	100	110	120
Factor	1.10	1.05	1.00	0.95	0.90

Data sheet | Solenoid valve, types EVR 2 - EVR 40 Version 2
**Extended capacity
Suction**
(continued)

Type	Pressure drop Δp [psi]	Suction vapour capacity Qe [TR] at evaporating temperature t_e [°F]							
		-40	-20	0	10	20	30	40	50
R134a (continued)									
EVR 20	1	0.72	1.03	1.41	1.62	1.85	2.10	2.37	2.66
	2	0.93	1.39	1.93	2.23	2.56	2.92	3.31	3.73
	3	1.02	1.60	2.28	2.67	3.08	3.52	4.00	4.51
EVR 22	1	0.83	1.18	1.60	1.85	2.11	2.40	2.70	3.04
	2	1.06	1.58	2.20	2.55	2.93	3.33	3.77	4.25
	3	1.16	1.83	2.61	3.04	3.51	4.02	4.56	5.15
EVR 25	3	1.67	2.63	3.74	4.36	5.04	5.77	6.55	7.39
EVR 32	3	2.85	4.49	6.39	7.46	8.61	9.85	11.19	12.63
EVR 40	3	4.12	6.49	9.24	10.79	12.46	14.25	16.19	18.27

The table values refer to the evaporator capacity and are given as a function of evaporating temperature t_e and pressure drop Δp across valve.

Capacities are based on:
Liquid temperature $t_l = 100$ °F
Subcooling = 0 °F
Superheat = 7 °F

Metric conversions
1 psi = 0.07 bar
 $\frac{5}{9}(t_1 \text{ °F} - 32) = t_2 \text{ °C}$
1 TR = 3.5 kW

Correction factors

When liquid temperature t_l ahead of the expansion valve is other than 100 °F, adjust the table capacities by multiplying them by the appropriate correction factor found in the following table.

Correction factors based on liquid temperature t_l

t_l [°F]	80	90	100	110	120
Factor	1.10	1.05	1.00	0.95	0.90

Data sheet | Solenoid valve, types EVR 2 - EVR 40 Version 2
**Extended capacity
Suction**
(continued)

Type	Pressure drop Δp [psi]	Suction vapour capacity Q_e [TR] at evaporating temperature t_e [°F]							
		-40	-20	0	10	20	30	40	50
R404A/R507									
EVR 2	1	0.02	0.03	0.04	0.05	0.05	0.06	0.07	0.07
	2	0.03	0.04	0.06	0.06	0.07	0.08	0.09	0.10
	3	0.04	0.05	0.07	0.08	0.09	0.10	0.11	0.13
EVR 3	1	0.04	0.06	0.07	0.08	0.09	0.11	0.12	0.13
	2	0.06	0.08	0.10	0.12	0.13	0.15	0.17	0.19
	3	0.07	0.09	0.12	0.14	0.16	0.18	0.20	0.23
EVR 4	1	0.10	0.14	0.18	0.21	0.24	0.27	0.30	0.33
	2	0.14	0.19	0.26	0.29	0.33	0.37	0.42	0.47
	3	0.16	0.23	0.31	0.35	0.40	0.45	0.51	0.57
EVR 6	1	0.13	0.18	0.24	0.27	0.31	0.35	0.39	0.44
	2	0.18	0.25	0.34	0.38	0.43	0.49	0.55	0.61
	3	0.22	0.30	0.41	0.46	0.53	0.60	0.67	0.75
EVR 8	1	0.16	0.22	0.29	0.33	0.37	0.42	0.47	0.52
	2	0.22	0.30	0.40	0.46	0.52	0.58	0.65	0.73
	3	0.26	0.36	0.48	0.55	0.63	0.71	0.80	0.89
EVR 10	1	0.28	0.38	0.51	0.58	0.65	0.73	0.82	0.92
	2	0.38	0.53	0.71	0.80	0.91	1.03	1.15	1.29
	3	0.45	0.63	0.85	0.97	1.11	1.25	1.40	1.57
EVR 15	1	0.43	0.59	0.78	0.89	1.00	1.13	1.27	1.41
	2	0.59	0.82	1.09	1.24	1.41	1.58	1.78	1.98
	3	0.70	0.98	1.31	1.50	1.71	1.93	2.16	2.42
EVR 18	1	0.56	0.77	1.02	1.16	1.31	1.48	1.66	1.85
	2	0.77	1.07	1.42	1.62	1.84	2.07	2.33	2.60
	3	0.91	1.28	1.72	1.97	2.23	2.52	2.83	3.16

The table values refer to the evaporator capacity and are given as a function of evaporating temperature t_e and pressure drop Δp across valve.

Capacities are based on:
Liquid temperature $t_l = 100$ °F
Subcooling = 0 °F
Superheat = 7 °F

Metric conversions
1 psi = 0.07 bar
 $\frac{5}{9} (t_1 - 32) = t_2$ °C
1 TR = 3.5 kW

Correction factors

When liquid temperature t_l ahead of the expansion valve is other than 100 °F, adjust the table capacities by multiplying them by the appropriate correction factor found in the following table.

Correction factors based on liquid temperature t_l

t_l [°F]	80	90	100	110	120
Factor	1.10	1.05	1.00	0.95	0.90

Data sheet | Solenoid valve, types EVR 2 - EVR 40 Version 2

Extended capacity

Suction
(continued)

Type	Pressure drop Δp [psi]	Suction vapour capacity Q_e [TR] at evaporating temperature t_e [°F]							
		-40	-20	0	10	20	30	40	50
R404A/R507 (continued)									
EVR 20	1	0.90	1.22	1.62	1.84	2.08	2.34	2.63	2.93
	2	1.22	1.69	2.26	2.57	2.92	3.29	3.69	4.12
	3	1.44	2.03	2.72	3.12	3.54	4.00	4.49	5.02
EVR 22	1	1.02	1.40	1.84	2.10	2.38	2.67	3.00	3.34
	2	1.40	1.93	2.57	2.94	3.33	3.75	4.21	4.70
	3	1.65	2.31	3.11	3.55	4.04	4.56	5.12	5.73
EVR 25	3	2.37	3.32	4.46	5.10	5.80	6.55	7.35	8.22
EVR 32	3	4.04	5.68	7.62	8.72	9.91	11.19	12.57	14.04
EVR 40	3	5.85	8.21	11.03	12.61	14.33	16.18	18.18	20.32

The table values refer to the evaporator capacity and are given as a function of evaporating temperature t_e and pressure drop Δp across valve.

Capacities are based on:
Liquid temperature $t_l = 100$ °F
Subcooling = 0 °F
Superheat = 7 °F

Metric conversions
1 psi = 0.07 bar
 $\frac{5}{9}(t_1 - 32) = t_2$ °C
1 TR = 3.5 kW

Correction factors

When liquid temperature t_l ahead of the expansion valve is other than 100 °F, adjust the table capacities by multiplying them by the appropriate correction factor found in the following table.

Correction factors based on liquid temperature t_l

t_l [°F]	80	90	100	110	120
Factor	1.10	1.05	1.00	0.95	0.90

Data sheet | Solenoid valve, types EVR 2 - EVR 40 Version 2
**Extended capacity
Suction
(continued)**

Type	Pressure drop Δp [psi]	Suction vapour capacity Q_e [TR] at evaporating temperature t_e [°F]							
		-40	-20	0	10	20	30	40	50
R410A									
EVR 2	1	0.04	0.05	0.06	0.07	0.08	0.09	0.09	0.10
	2	0.05	0.07	0.09	0.10	0.11	0.12	0.13	0.15
	3	0.06	0.08	0.10	0.12	0.13	0.15	0.16	0.18
EVR 3	1	0.07	0.09	0.11	0.12	0.14	0.15	0.17	0.19
	2	0.09	0.12	0.16	0.17	0.19	0.22	0.24	0.26
	3	0.11	0.15	0.19	0.21	0.24	0.26	0.29	0.32
EVR 4	1	0.17	0.22	0.28	0.31	0.35	0.39	0.43	0.47
	2	0.23	0.30	0.39	0.44	0.49	0.54	0.60	0.66
	3	0.27	0.37	0.47	0.53	0.60	0.66	0.73	0.81
EVR 6	1	0.22	0.29	0.37	0.41	0.46	0.51	0.56	0.62
	2	0.30	0.40	0.51	0.57	0.64	0.71	0.79	0.87
	3	0.36	0.48	0.62	0.70	0.78	0.87	0.96	1.06
EVR 8	1	0.26	0.34	0.44	0.49	0.54	0.60	0.67	0.73
	2	0.36	0.48	0.61	0.68	0.76	0.85	0.94	1.03
	3	0.43	0.57	0.74	0.83	0.93	1.03	1.14	1.26
EVR 10	1	0.46	0.60	0.77	0.86	0.96	1.06	1.17	1.29
	2	0.63	0.84	1.08	1.21	1.35	1.50	1.65	1.82
	3	0.76	1.01	1.30	1.47	1.64	1.82	2.02	2.22
EVR 15	1	0.71	0.93	1.18	1.32	1.48	1.64	1.81	1.99
	2	0.97	1.29	1.66	1.86	2.07	2.30	2.55	2.81
	3	1.16	1.56	2.01	2.26	2.52	2.81	3.10	3.42
EVR 18	1	0.92	1.21	1.55	1.73	1.93	2.14	2.37	2.61
	2	1.28	1.69	2.17	2.43	2.71	3.02	3.33	3.67
	3	1.52	2.04	2.63	2.96	3.30	3.67	4.06	4.48

The table values refer to the evaporator capacity and are given as a function of evaporating temperature t_e and pressure drop Δp across valve.

Capacities are based on:
Liquid temperature $t_l = 100$ °F
Subcooling = 0 °F
Superheat = 7 °F

Metric conversions
1 psi = 0.07 bar
 $\frac{5}{9}(t_1 - 32) = t_2$ °C
1 TR = 3.5 kW

Correction factors

When liquid temperature t_l ahead of the expansion valve is other than 100 °F, adjust the table capacities by multiplying them by the appropriate correction factor found in the following table.

Correction factors based on liquid temperature t_l

t_l [°F]	80	90	100	110	120
Factor	1.10	1.05	1.00	0.95	0.90

Data sheet | Solenoid valve, types EVR 2 - EVR 40 Version 2

**Extended capacity
Suction**
(continued)

Type	Pressure drop Δp [psi]	Suction vapour capacity Qe [TR] at evaporating temperature t_e [°F]							
		-40	-20	0	10	20	30	40	50
R410A (continued)									
EVR 20	1	1.47	1.92	2.46	2.75	3.07	3.40	3.76	4.13
	2	2.02	2.68	3.44	3.86	4.31	4.78	5.29	5.82
	3	2.42	3.23	4.17	4.69	5.24	5.83	6.45	7.11
EVR 22	1	1.67	2.19	2.80	3.14	3.50	3.88	4.28	4.72
	2	2.31	3.06	3.92	4.40	4.91	5.45	6.03	6.64
	3	2.75	3.69	4.76	5.35	5.98	6.64	7.35	8.10
EVR 25	3	3.95	5.29	6.83	7.67	8.58	9.54	10.55	11.63
EVR 32	3	6.76	9.04	11.67	13.11	14.66	16.30	18.04	19.88
EVR 40	3	9.77	13.08	16.88	18.97	21.20	23.57	26.09	28.76

The table values refer to the evaporator capacity and are given as a function of evaporating temperature t_e and pressure drop Δp across valve.

Capacities are based on:
Liquid temperature $t_l = 100$ °F
Subcooling = 0 °F
Superheat = 7 °F

Metric conversions
1 psi = 0.07 bar
 $\frac{5}{9} (t_1 - 32) = t_2$ °C
1 TR = 3.5 kW

Correction factors

When liquid temperature t_l ahead of the expansion valve is other than 100 °F, adjust the table capacities by multiplying them by the appropriate correction factor found in the following table.

Correction factors based on liquid temperature t_l

t_l [°F]	80	90	100	110	120
Factor	1.10	1.05	1.00	0.95	0.90

Data sheet | Solenoid valve, types EVR 2 - EVR 40 Version 2
**Extended capacity
Suction**
(continued)

Type	Pressure drop Δp [psi]	Suction vapour capacity Q_e [TR] at evaporating temperature t_e [°F]							
		-40	-20	0	10	20	30	40	50
R32									
EVR 2	1	0.05	0.06	0.08	0.09	0.10	0.11	0.12	0.13
	2	0.07	0.09	0.11	0.13	0.14	0.16	0.17	0.19
	3	0.08	0.11	0.14	0.16	0.17	0.19	0.21	0.23
EVR 3	1	0.09	0.12	0.15	0.16	0.18	0.20	0.22	0.24
	2	0.12	0.16	0.21	0.23	0.25	0.28	0.31	0.34
	3	0.15	0.20	0.25	0.28	0.31	0.34	0.38	0.41
EVR 4	1	0.23	0.29	0.37	0.41	0.46	0.50	0.55	0.60
	2	0.31	0.41	0.52	0.58	0.64	0.71	0.78	0.85
	3	0.38	0.50	0.63	0.70	0.78	0.86	0.95	1.04
EVR 6	1	0.30	0.39	0.48	0.54	0.60	0.66	0.72	0.79
	2	0.41	0.54	0.68	0.76	0.84	0.93	1.02	1.11
	3	0.49	0.65	0.82	0.92	1.02	1.13	1.24	1.36
EVR 8	1	0.35	0.46	0.58	0.64	0.71	0.78	0.86	0.94
	2	0.49	0.64	0.81	0.90	1.00	1.10	1.21	1.33
	3	0.59	0.77	0.98	1.10	1.22	1.34	1.48	1.62
EVR 10	1	0.63	0.81	1.02	1.13	1.25	1.38	1.52	1.66
	2	0.87	1.13	1.43	1.59	1.76	1.95	2.14	2.34
	3	1.04	1.36	1.73	1.93	2.15	2.37	2.61	2.86
EVR 15	1	0.96	1.25	1.57	1.74	1.93	2.13	2.34	2.56
	2	1.33	1.74	2.20	2.45	2.72	3.00	3.29	3.60
	3	1.59	2.10	2.67	2.98	3.31	3.65	4.02	4.40
EVR 18	1	1.26	1.63	2.05	2.28	2.53	2.79	3.06	3.35
	2	1.74	2.27	2.88	3.21	3.55	3.92	4.31	4.72
	3	2.09	2.75	3.49	3.90	4.33	4.78	5.26	5.76
EVR 20	1	2.00	2.59	3.26	3.62	4.01	4.42	4.85	5.31
	2	2.77	3.61	4.56	5.09	5.64	6.22	6.84	7.48
	3	3.31	4.36	5.54	6.18	6.86	7.58	8.34	9.13
EVR 22	1	2.28	2.95	3.71	4.13	4.57	5.04	5.54	6.06
	2	3.16	4.11	5.20	5.80	6.43	7.10	7.80	8.53
	3	3.78	4.97	6.32	7.05	7.83	8.65	9.51	10.41

The table values refer to the evaporator capacity and are given as a function of evaporating temperature t_e and pressure drop Δp across valve.

Capacities are based on:
Liquid temperature $t_l = 100$ °F
Subcooling = 0 °F
Superheat = 7 °F

Metric conversions
1 psi = 0.07 bar
 $\frac{5}{9}(t_1 \text{ °F} - 32) = t_2 \text{ °C}$
1 TR = 3.5 kW

Correction factors

When liquid temperature t_l ahead of the expansion valve is other than 100 °F, adjust the table capacities by multiplying them by the appropriate correction factor found in the following table.

Correction factors based on liquid temperature t_l

t_l [°F]	80	90	100	110	120
Factor	1.10	1.05	1.00	0.95	0.90

Data sheet | Solenoid valve, types EVR 2 - EVR 40 Version 2
**Extended capacity
Suction**
(continued)

Type	Pressure drop Δp [psi]	Suction vapour capacity Qe [TR] at evaporating temperature t_e [°F]							
		-40	-20	0	10	20	30	40	50
R290									
EVR 2	1	0.04	0.05	0.06	0.07	0.08	0.09	0.09	0.10
	2	0.05	0.06	0.08	0.10	0.11	0.12	0.13	0.15
	3	0.06	0.08	0.10	0.11	0.13	0.14	0.16	0.18
EVR 3	1	0.06	0.08	0.11	0.12	0.14	0.15	0.17	0.19
	2	0.09	0.12	0.15	0.17	0.19	0.21	0.24	0.26
	3	0.10	0.14	0.18	0.21	0.23	0.26	0.29	0.32
EVR 4	1	0.16	0.21	0.27	0.31	0.35	0.39	0.43	0.47
	2	0.22	0.29	0.38	0.43	0.48	0.54	0.60	0.67
	3	0.26	0.35	0.46	0.52	0.59	0.66	0.73	0.81
EVR 6	1	0.21	0.28	0.36	0.41	0.45	0.51	0.56	0.62
	2	0.29	0.38	0.50	0.56	0.63	0.71	0.79	0.87
	3	0.33	0.46	0.60	0.68	0.77	0.86	0.96	1.06
EVR 8	1	0.25	0.33	0.43	0.48	0.54	0.60	0.67	0.74
	2	0.34	0.46	0.60	0.67	0.76	0.84	0.94	1.04
	3	0.40	0.55	0.72	0.81	0.91	1.02	1.14	1.26
EVR 10	1	0.44	0.59	0.76	0.85	0.95	1.06	1.18	1.30
	2	0.60	0.81	1.05	1.19	1.33	1.49	1.65	1.83
	3	0.70	0.96	1.27	1.43	1.61	1.80	2.01	2.23
EVR 15	1	0.68	0.90	1.16	1.31	1.47	1.64	1.82	2.01
	2	0.92	1.25	1.62	1.83	2.05	2.29	2.55	2.82
	3	1.08	1.49	1.95	2.21	2.48	2.78	3.09	3.43
EVR 18	1	0.89	1.18	1.52	1.72	1.92	2.14	2.38	2.63
	2	1.21	1.63	2.12	2.39	2.69	3.00	3.33	3.69
	3	1.42	1.94	2.55	2.89	3.25	3.64	4.05	4.49
EVR 20	1	1.41	1.88	2.42	2.72	3.05	3.40	3.77	4.17
	2	1.92	2.59	3.36	3.80	4.26	4.76	5.29	5.85
	3	2.25	3.08	4.05	4.58	5.16	5.77	6.42	7.12
EVR 22	1	1.61	2.14	2.76	3.10	3.48	3.87	4.30	4.75
	2	2.19	2.95	3.84	4.33	4.86	5.43	6.03	6.68
	3	2.57	3.52	4.62	5.23	5.88	6.58	7.33	8.12

The table values refer to the evaporator capacity and are given as a function of evaporating temperature t_e and pressure drop Δp across valve.

Capacities are based on:
Liquid temperature $t_l = 100$ °F
Subcooling = 0 °F
Superheat = 7 °F

Metric conversions
1 psi = 0.07 bar
 $\frac{5}{9}(t_1 - 32) = t_2$ °C
1 TR = 3.5 kW

Correction factors

When liquid temperature t_l ahead of the expansion valve is other than 100 °F, adjust the table capacities by multiplying them by the appropriate correction factor found in the following table.

Correction factors based on liquid temperature t_l

t_l [°F]	80	90	100	110	120
Factor	1.10	1.05	1.00	0.95	0.90

Data sheet | Solenoid valve, types EVR 2 - EVR 40 Version 2
**Extended capacity
Suction**
(continued)

Type	Pressure drop Δp [psi]	Suction vapour capacity Q_e [TR] at evaporating temperature t_e [°F]							
		-40	-20	0	10	20	30	40	50
R600a									
EVR 2	1	0.02	0.02	0.03	0.04	0.05	0.05	0.06	0.07
	2	0.02	0.03	0.04	0.05	0.06	0.07	0.08	0.09
	3	0.02	0.03	0.05	0.06	0.07	0.08	0.10	0.11
EVR 3	1	0.03	0.04	0.06	0.07	0.08	0.09	0.10	0.12
	2	0.03	0.06	0.08	0.10	0.11	0.13	0.14	0.16
	3	0.03	0.06	0.09	0.11	0.13	0.15	0.17	0.20
EVR 4	1	0.07	0.11	0.15	0.18	0.20	0.23	0.26	0.30
	2	0.09	0.14	0.20	0.24	0.28	0.32	0.36	0.41
	3	0.09	0.15	0.23	0.28	0.33	0.38	0.43	0.49
EVR 6	1	0.10	0.14	0.20	0.23	0.27	0.30	0.35	0.39
	2	0.11	0.18	0.27	0.31	0.36	0.42	0.48	0.54
	3	0.11	0.20	0.31	0.36	0.43	0.50	0.57	0.65
EVR 8	1	0.12	0.17	0.24	0.28	0.32	0.36	0.41	0.46
	2	0.13	0.22	0.32	0.37	0.43	0.50	0.57	0.64
	3	0.13	0.24	0.36	0.43	0.51	0.59	0.68	0.77
EVR 10	1	0.21	0.30	0.42	0.49	0.56	0.64	0.73	0.82
	2	0.24	0.39	0.56	0.66	0.76	0.88	1.00	1.13
	3	0.24	0.42	0.64	0.77	0.90	1.04	1.19	1.36
EVR 15	1	0.32	0.47	0.65	0.75	0.86	0.99	1.12	1.26
	2	0.36	0.60	0.86	1.01	1.18	1.35	1.54	1.74
	3	0.36	0.65	0.99	1.18	1.38	1.60	1.84	2.09
EVR 18	1	0.41	0.61	0.85	0.98	1.13	1.29	1.46	1.65
	2	0.48	0.78	1.13	1.33	1.54	1.77	2.02	2.28
	3	0.48	0.85	1.30	1.54	1.81	2.10	2.41	2.74
EVR 20	1	0.66	0.97	1.35	1.56	1.79	2.05	2.32	2.61
	2	0.76	1.24	1.79	2.10	2.44	2.81	3.20	3.62
	3	0.76	1.34	2.06	2.45	2.87	3.33	3.82	4.34
EVR 22	1	0.75	1.11	1.54	1.78	2.05	2.33	2.65	2.98
	2	0.86	1.41	2.04	2.40	2.78	3.20	3.65	4.13
	3	0.86	1.53	2.34	2.79	3.28	3.79	4.35	4.95

The table values refer to the evaporator capacity and are given as a function of evaporating temperature t_e and pressure drop Δp across valve.

Capacities are based on:
Liquid temperature $t_l = 100$ °F
Subcooling = 0 °F
Superheat = 7 °F

Metric conversions
1 psi = 0.07 bar
 $5/9 (t_1 \text{ °F} - 32) = t_2 \text{ °C}$
1 TR = 3.5 kW

Correction factors

When liquid temperature t_l ahead of the expansion valve is other than 100 °F, adjust the table capacities by multiplying them by the appropriate correction factor found in the following table.

Correction factors based on liquid temperature t_l

t_l [°F]	80	90	100	110	120
Factor	1.10	1.05	1.00	0.95	0.90

Extended capacity

Suction

(continued)

Hot gas defrosting

With hot gas defrosting, it is not normally possible to select a valve from condensing temperature t_c and evaporating temperature t_e .

This is because as a rule, the pressure in the evaporator quickly rises to a value near that of the condensing pressure. It remains at this value until the defrosting is finished.

In most cases, the valve will be selected from condensing temperature t_c and pressure drop Δp across the valve, as shown in the example for heat recovery.

Heat recovery

The following is given:

- Refrigerant = R22/R407C
- Evaporating temperature $t_e = 86^\circ\text{F}$
- Condensing temperature $t_c = 104^\circ\text{F}$
- Hot gas temperature ahead of valve $t_h = 185^\circ\text{F}$
- Heat recovery condenser yield $Q_h = 8\text{ kW}$

The capacity table for R22/R407C with $t_c = 104^\circ\text{F}$ gives the capacity for an EVR 10 as 8.9 kW, when pressure drop Δp is 2.9 psi.

The required capacity is calculated as:

$$Q_{table} = f_{evaporator} \times f_{hot_temperature} \times Q_h$$

The correction factor for $t_e = 86^\circ\text{F}$ is given in the table as 0.95.

The correction for hot gas temperature $t_h = 185^\circ\text{F}$ has been calculated as 4% which corresponds to a factor of 1.04.

Q_h must be corrected with factors found:

With $\Delta p = 2.9\text{ psi}$

is $Q_h = 8.71 \times 0.95 \times 1.04 = 8.6\text{ kW}$.

With $\Delta p = 1.4\text{ psi}$, Q_h becomes only $6.19 \times 0.95 \times 1.04 = 6.1\text{ kW}$.

An EVR 6 would also be able to give the required capacity, but with Δp at approximately 14.5 psi, the EVR 6 is therefore too small.

The EVR 15 is so large that it is doubtful whether the necessary Δp of approximately 1.4 psi could be obtained.

An EVR 15 would therefore be too large.

Result: An EVR 10 is the correct valve for the given conditions.

**Extended capacity
Hot gas**

Type	Pressure drop across valve Δp [psi]	Hot gas capacity Q_h [TR], Evaporating temp. $t_e = 40^\circ\text{F}$, Hot gas temp. $t_h = t_c + 40^\circ\text{F}$, Subcooling $\Delta t_{\text{sub}} = 10^\circ\text{F}$				
		Condensing temperature t_c [$^\circ\text{F}$]				
		60	80	100	120	140
R22/R407C						
EVR 2	2	0.16	0.17	0.18	0.19	0.19
	5	0.25	0.27	0.28	0.29	0.29
	10	0.35	0.38	0.40	0.41	0.41
	15	0.41	0.45	0.48	0.50	0.50
	20	0.47	0.51	0.55	0.57	0.57
	25	0.51	0.56	0.60	0.63	0.63
EVR 3	2	0.29	0.31	0.33	0.33	0.33
	5	0.45	0.49	0.51	0.53	0.53
	10	0.62	0.68	0.71	0.74	0.74
	15	0.74	0.81	0.86	0.89	0.90
	20	0.84	0.92	0.98	1.02	1.03
	25	0.91	1.01	1.08	1.13	1.14
EVR 4	2	0.73	0.78	0.82	0.84	0.84
	5	1.14	1.22	1.29	1.33	1.32
	10	1.57	1.70	1.80	1.86	1.86
	15	1.87	2.05	2.17	2.25	2.25
	20	2.11	2.32	2.48	2.57	2.58
	25	2.30	2.54	2.73	2.84	2.86
EVR 6	2	0.95	1.02	1.08	1.10	1.10
	5	1.49	1.60	1.69	1.73	1.73
	10	2.05	2.23	2.35	2.43	2.43
	15	2.45	2.68	2.84	2.94	2.95
	20	2.76	3.03	3.24	3.36	3.38
	25	3.01	3.33	3.57	3.72	3.75
EVR 8	2	1.14	1.22	1.28	1.31	1.31
	5	1.77	1.91	2.01	2.07	2.06
	10	2.45	2.65	2.80	2.89	2.89
	15	2.92	3.19	3.39	3.51	3.51
	20	3.29	3.61	3.86	4.01	4.03
	25	3.58	3.96	4.26	4.43	4.46

Correction factors

The table values refer to hot gas capacity and are given as a function of condensing temperature t_c and pressure drop Δp across the valve.

Capacities are based on:
Hot gas temperature = $t_c + 40^\circ\text{F}$
Subcooling = 10°F
Evaporating temperature = 40°F
Superheat = 0°F

For each additional 10°F of superheat above 40°F , the table capacities must be reduced by 1%.

When the valve is used in a hot gas defrost circuit, evaporator temperature affects the capacity. When the evaporator temperature differs from 40°F , adjust the table capacities by multiplying them by the appropriate correction factor found in the following table.

Metric conversions

1 psi = 0.07 bar
 $\frac{5}{9}(t_1 - 32) = t_2$
1 TR = 3.5 kW

Correction factors for t_h and t_e

t_e [$^\circ\text{F}$]	-40	-20	0	20	40	50
Factor	1.18	1.14	1.09	1.04	1	0.97

**Extended capacity
Hot gas**

Type	Pressure drop across valve Δp [psi]	Hot gas capacity Q_h [TR], Evaporating temp. $t_e = 40^\circ\text{F}$, Hot gas temp. $t_h = t_c + 40^\circ\text{F}$, Subcooling $\Delta t_{\text{sub}} = 10^\circ\text{F}$				
		Condensing temperature t_c [$^\circ\text{F}$]				
		60	80	100	120	140
R22/R407C (continued)						
EVR 10	2	1.84	1.99	2.12	2.22	2.28
	5	2.86	3.12	3.33	3.49	3.59
	10	3.94	4.32	4.64	4.88	5.03
	15	4.69	5.19	5.60	5.92	6.11
	20	5.26	5.87	6.37	6.75	6.99
	25	5.71	6.42	7.01	7.46	7.75
EVR 15	2	2.83	3.07	3.27	3.43	3.51
	5	4.40	4.80	5.13	5.38	5.53
	10	6.06	6.65	7.15	7.52	7.75
	15	7.22	7.99	8.63	9.11	9.41
	20	8.10	9.04	9.81	10.40	10.77
	25	8.79	9.89	10.80	11.49	11.93
EVR 18	2	3.70	4.02	4.28	4.48	4.60
	5	5.76	6.28	6.71	7.04	7.23
	10	7.93	8.71	9.36	9.85	10.14
	15	9.45	10.46	11.29	11.93	12.31
	20	10.61	11.83	12.84	13.61	14.09
	25	11.51	12.95	14.14	15.05	15.62
EVR 20	2	5.87	6.38	6.79	7.11	7.30
	5	9.14	9.96	10.65	11.17	11.48
	10	12.58	13.82	14.84	15.62	16.09
	15	14.99	16.59	17.91	18.92	19.53
	20	16.82	18.76	20.37	21.59	22.35
	25	18.26	20.54	22.43	23.87	24.77
EVR 22	2	6.70	7.27	7.75	8.11	8.32
	5	10.43	11.36	12.15	12.74	13.09
	10	14.35	15.76	16.93	17.82	18.35
	15	17.10	18.92	20.43	21.57	22.27
	20	19.18	21.40	23.23	24.63	25.49
	25	20.83	23.43	25.58	27.22	28.25

Correction factors

The table values refer to hot gas capacity and are given as a function of condensing temperature t_c and pressure drop Δp across the valve.

Capacities are based on:
Hot gas temperature = $t_c + 40^\circ\text{F}$
Subcooling = 10°F
Evaporating temperature = 40°F
Superheat = 0°F

For each additional 10°F of superheat above 40°F , the table capacities must be reduced by 1%.

When the valve is used in a hot gas defrost circuit, evaporator temperature affects the capacity. When the evaporator temperature differs from 40°F , adjust the table capacities by multiplying them by the appropriate correction factor found in the following table.

Metric conversions

1 psi = 0.07 bar
 $\frac{5}{9}(t_1 - 32) = t_2$ °C
1 TR = 3.5 kW

Correction factors for t_h and t_e

t_e [$^\circ\text{F}$]	-40	-20	0	20	40	50
Factor	1.18	1.14	1.09	1.04	1	0.97

Data sheet | Solenoid valve, types EVR 2 - EVR 40 Version 2

**Extended capacity
Hot gas**

Correction factors

The table values refer to hot gas capacity and are given as a function of condensing temperature t_c and pressure drop Δp across the valve.

Capacities are based on:
Hot gas temperature = $t_c + 40$ °F
Subcooling = 10 °F

Evaporating temperature = 40 °F
Superheat = 0 °F

For each additional 10 °F of superheat above 40 °F, the table capacities must be reduced by 1%.

When the valve is used in a hot gas defrost circuit, evaporator temperature affects the capacity. When the evaporator temperature differs from 40 °F, adjust the table capacities by multiplying them by the appropriate correction factor found in the following table.

Metric conversions

1 psi = 0.07 bar

$\frac{5}{9}(t_1 \text{ °F} - 32) = t_2 \text{ °C}$

1 TR = 3.5 kW

Type	Pressure drop across valve Δp [psi]	Hot gas capacity Q_h [TR], Evaporating temp. $t_e = 40$ °F, Hot gas temp. $t_h = t_c + 40$ °F, Subcooling $\Delta t_{sub} = 10$ °F				
		Condensing temperature t_c [°F]				
		60	80	100	120	140
R22/R407C (continued)						
EVR 25	5	14.97	16.31	17.44	18.29	18.79
	10	20.60	22.62	24.30	25.57	26.34
	15	24.54	27.15	29.32	30.97	31.97
	20	27.54	30.72	33.35	35.35	36.60
	25	29.90	33.63	36.72	39.07	40.55
EVR 32	5	25.58	27.87	29.80	31.25	32.10
	10	35.21	38.65	41.53	43.70	45.01
	15	41.94	46.40	50.11	52.92	54.64
	20	47.06	52.49	56.99	60.41	62.54
	25	51.09	57.48	62.75	66.77	69.30
EVR 40	5	37.00	40.32	43.10	45.20	46.44
	10	50.93	55.91	60.07	63.22	65.10
	15	60.66	67.12	72.48	76.55	79.04
	20	68.07	75.93	82.44	87.39	90.46
	25	73.90	83.14	90.76	96.58	100.24

Correction factors for t_h and t_e

t_e [°F]	-40	-20	0	20	40	50
Factor	1.18	1.14	1.09	1.04	1	0.97

**Extended capacity
Hot gas**

Type	Pressure drop across valve Δp [psi]	Hot gas capacity Q_h [TR], Evaporating temp. $t_e = 40^\circ\text{F}$, Hot gas temp. $t_h = t_c + 40^\circ\text{F}$, Subcooling $\Delta t_{sub} = 10^\circ\text{F}$				
		Condensing temperature t_c [$^\circ\text{F}$]				
		60	80	100	120	140
R134a						
EVR 2	2	0.12	0.13	0.14	0.14	0.14
	5	0.18	0.20	0.21	0.22	0.23
	10	0.25	0.27	0.30	0.31	0.32
	15	0.29	0.33	0.35	0.37	0.38
	20	0.32	0.36	0.40	0.42	0.43
	25	0.33	0.39	0.43	0.46	0.48
EVR 3	2	0.21	0.23	0.25	0.26	0.26
	5	0.33	0.36	0.39	0.40	0.41
	10	0.44	0.49	0.53	0.56	0.57
	15	0.52	0.59	0.64	0.67	0.69
	20	0.57	0.65	0.72	0.76	0.78
	25	0.60	0.70	0.78	0.84	0.86
EVR 4	2	0.54	0.59	0.62	0.65	0.65
	5	0.83	0.91	0.97	1.01	1.03
	10	1.12	1.25	1.34	1.41	1.43
	15	1.30	1.47	1.60	1.69	1.73
	20	1.43	1.64	1.81	1.92	1.97
	25	1.51	1.77	1.97	2.10	2.17
EVR 6	2	0.71	0.77	0.82	0.85	0.86
	5	1.09	1.19	1.27	1.32	1.34
	10	1.46	1.63	1.76	1.84	1.87
	15	1.71	1.93	2.10	2.21	2.26
	20	1.87	2.15	2.36	2.51	2.58
	25	1.98	2.32	2.58	2.75	2.84
EVR 8	2	0.84	0.91	0.97	1.01	1.02
	5	1.29	1.42	1.52	1.58	1.60
	10	1.74	1.94	2.09	2.19	2.23
	15	2.03	2.30	2.50	2.64	2.69
	20	2.23	2.56	2.82	2.99	3.07
	25	2.35	2.76	3.07	3.28	3.38

Correction factors

The table values refer to hot gas capacity and are given as a function of condensing temperature t_c and pressure drop Δp across the valve.

Capacities are based on:
Hot gas temperature = $t_c + 40^\circ\text{F}$
Subcooling = 10°F
Evaporating temperature = 40°F
Superheat = 0°F

For each additional 10°F of superheat above 40°F , the table capacities must be reduced by 1%.

When the valve is used in a hot gas defrost circuit, evaporator temperature affects the capacity. When the evaporator temperature differs from 40°F , adjust the table capacities by multiplying them by the appropriate correction factor found in the following table.

Metric conversions

1 psi = 0.07 bar
 $\frac{5}{9}(t_1 - 32) = t_2$ °C
1 TR = 3.5 kW

Correction factors for t_h and t_e

t_e [$^\circ\text{F}$]	-40	-20	0	20	40	50
Factor	1.18	1.14	1.09	1.04	1	0.97

**Extended capacity
Hot gas**

Type	Pressure drop across valve Δp [psi]	Hot gas capacity Q_h [TR], Evaporating temp. $t_e = 40^\circ\text{F}$, Hot gas temp. $t_h = t_c + 40^\circ\text{F}$, Subcooling $\Delta t_{\text{sub}} = 10^\circ\text{F}$				
		Condensing temperature t_c [$^\circ\text{F}$]				
		60	80	100	120	140
R134a (continued)						
EVR 10	2	1.48	1.61	1.71	1.78	1.80
	5	2.28	2.50	2.67	2.78	2.82
	10	3.08	3.42	3.69	3.87	3.93
	15	3.59	4.05	4.41	4.65	4.75
	20	3.93	4.52	4.97	5.27	5.41
	25	4.15	4.87	5.41	5.79	5.97
EVR 15	2	2.29	2.49	2.64	2.74	2.77
	5	3.52	3.85	4.12	4.29	4.34
	10	4.74	5.27	5.69	5.96	6.06
	15	5.52	6.24	6.79	7.17	7.32
	20	6.05	6.95	7.65	8.12	8.34
	25	6.40	7.49	8.34	8.91	9.19
EVR 18	2	2.99	3.25	3.46	3.59	3.62
	5	4.60	5.05	5.39	5.61	5.68
	10	6.21	6.90	7.44	7.80	7.93
	15	7.23	8.17	8.89	9.38	9.58
	20	7.92	9.10	10.02	10.63	10.91
	25	8.37	9.81	10.91	11.67	12.03
EVR 20	2	4.75	5.16	5.48	5.69	5.75
	5	7.30	8.00	8.55	8.90	9.02
	10	9.84	10.95	11.81	12.37	12.58
	15	11.47	12.96	14.11	14.88	15.20
	20	12.56	14.44	15.89	16.87	17.31
	25	13.28	15.56	17.31	18.51	19.09
EVR 22	2	5.41	5.89	6.25	6.49	6.56
	5	8.33	9.13	9.75	10.15	10.28
	10	11.23	12.49	13.46	14.11	14.35
	15	13.08	14.78	16.09	16.97	17.34
	20	14.33	16.47	18.12	19.24	19.74
	25	15.15	17.74	19.74	21.11	21.77

Correction factors

The table values refer to hot gas capacity and are given as a function of condensing temperature t_c and pressure drop Δp across the valve.

Capacities are based on:
Hot gas temperature = $t_c + 40^\circ\text{F}$
Subcooling = 10°F
Evaporating temperature = 40°F
Superheat = 0°F

For each additional 10°F of superheat above 40°F , the table capacities must be reduced by 1%.

When the valve is used in a hot gas defrost circuit, evaporator temperature affects the capacity. When the evaporator temperature differs from 40°F , adjust the table capacities by multiplying them by the appropriate correction factor found in the following table.

Metric conversions

1 psi = 0.07 bar
 $\frac{5}{9}(t_1 - 32) = t_2$ °C
1 TR = 3.5 kW

Correction factors for t_h and t_e

t_e [$^\circ\text{F}$]	-40	-20	0	20	40	50
Factor	1.18	1.14	1.09	1.04	1	0.97

Data sheet | Solenoid valve, types EVR 2 - EVR 40 Version 2

**Extended capacity
Hot gas**

Correction factors

The table values refer to hot gas capacity and are given as a function of condensing temperature t_c and pressure drop Δp across the valve.

Capacities are based on:
Hot gas temperature = $t_c + 40$ °F
Subcooling = 10 °F

Evaporating temperature = 40 °F

Superheat = 0 °F

For each additional 10 °F of superheat above 40 °F, the table capacities must be reduced by 1%.

When the valve is used in a hot gas defrost circuit, evaporator temperature affects the capacity. When the evaporator temperature differs from 40 °F, adjust the table capacities by multiplying them by the appropriate correction factor found in the following table.

Metric conversions

1 psi = 0.07 bar

$\frac{5}{9}(t_1 \text{ °F} - 32) = t_2 \text{ °C}$

1 TR = 3.5 kW

Type	Pressure drop across valve Δp [psi]	Hot gas capacity Q_h [TR], Evaporating temp. $t_e = 40$ °F, Hot gas temp. $t_h = t_c + 40$ °F, Subcooling $\Delta t_{sub} = 10$ °F				
		Condensing temperature t_c [°F]				
		60	80	100	120	140
R134a (continued)						
EVR 25	5	11.95	13.10	14.00	14.57	14.76
	10	16.11	17.93	19.33	20.25	20.60
	15	18.77	21.21	23.10	24.36	24.89
	20	20.56	23.64	26.01	27.61	28.34
	25	21.75	25.47	28.34	30.30	31.25
EVR 32	5	20.42	22.39	23.92	24.91	25.22
	10	27.54	30.63	33.03	34.60	35.20
	15	32.08	36.25	39.47	41.62	42.53
	20	35.14	40.40	44.44	47.19	48.43
	25	37.16	43.53	48.42	51.78	53.40
EVR 40	5	29.54	32.39	34.60	36.03	36.49
	10	39.83	44.31	47.77	50.06	50.91
	15	46.40	52.44	57.09	60.21	61.51
	20	50.83	58.43	64.29	68.26	70.06
	25	53.76	62.96	70.05	74.90	77.24

Correction factors for t_h and t_e

t_e [°F]	-40	-20	0	20	40	50
Factor	1.18	1.14	1.09	1.04	1	0.97

**Extended capacity
Hot gas**

Type	Pressure drop across valve Δp [psi]	Hot gas capacity Q_h [TR], Evaporating temp. $t_e = 40^\circ\text{F}$, Hot gas temp. $t_h = t_c + 40^\circ\text{F}$, Subcooling $\Delta t_{\text{sub}} = 10^\circ\text{F}$				
		Condensing temperature t_c [$^\circ\text{F}$]				
		60	80	100	120	140
R404A/R507						
EVR 2	2	0.14	0.15	0.15	0.14	0.13
	5	0.22	0.23	0.23	0.23	0.21
	10	0.30	0.32	0.32	0.32	0.29
	15	0.36	0.38	0.39	0.39	0.36
	20	0.40	0.43	0.44	0.44	0.41
	25	0.44	0.47	0.49	0.49	0.45
EVR 3	2	0.25	0.26	0.27	0.26	0.24
	5	0.39	0.41	0.42	0.41	0.38
	10	0.54	0.57	0.58	0.57	0.53
	15	0.65	0.68	0.70	0.69	0.64
	20	0.73	0.78	0.80	0.79	0.74
	25	0.79	0.85	0.88	0.88	0.82
EVR 4	2	0.63	0.66	0.67	0.65	0.60
	5	0.98	1.03	1.05	1.03	0.95
	10	1.36	1.43	1.46	1.44	1.34
	15	1.63	1.72	1.77	1.75	1.62
	20	1.83	1.96	2.02	2.00	1.86
	25	2.00	2.15	2.22	2.21	2.06
EVR 6	2	0.83	0.86	0.87	0.86	0.79
	5	1.29	1.35	1.37	1.35	1.25
	10	1.78	1.88	1.92	1.88	1.75
	15	2.13	2.26	2.32	2.28	2.12
	20	2.40	2.56	2.64	2.61	2.43
	25	2.61	2.81	2.91	2.89	2.70
EVR 8	2	0.98	1.03	1.04	1.02	0.94
	5	1.53	1.61	1.63	1.60	1.48
	10	2.12	2.23	2.28	2.24	2.08
	15	2.53	2.69	2.76	2.72	2.53
	20	2.86	3.05	3.14	3.11	2.90
	25	3.11	3.35	3.47	3.44	3.21

Correction factors

The table values refer to hot gas capacity and are given as a function of condensing temperature t_c and pressure drop Δp across the valve.

Capacities are based on:
Hot gas temperature = $t_c + 40^\circ\text{F}$
Subcooling = 10°F
Evaporating temperature = 40°F
Superheat = 0°F

For each additional 10°F of superheat above 40°F , the table capacities must be reduced by 1%.

When the valve is used in a hot gas defrost circuit, evaporator temperature affects the capacity. When the evaporator temperature differs from 40°F , adjust the table capacities by multiplying them by the appropriate correction factor found in the following table.

Metric conversions

1 psi = 0.07 bar
 $\frac{5}{9}(t_1 - 32) = t_2$
1 TR = 3.5 kW

Correction factors for t_h and t_e

t_e [$^\circ\text{F}$]	-40	-20	0	20	40	50
Factor	1.18	1.14	1.09	1.04	1	0.97

**Extended capacity
Hot gas**

Type	Pressure drop across valve Δp [psi]	Hot gas capacity Q_h [TR], Evaporating temp. $t_e = 40^\circ\text{F}$, Hot gas temp. $t_h = t_c + 40^\circ\text{F}$, Subcooling $\Delta t_{\text{sub}} = 10^\circ\text{F}$				
		Condensing temperature t_c [$^\circ\text{F}$]				
		60	80	100	120	140
R404A/R507 (continued)						
EVR 10	2	1.74	1.81	1.84	1.80	1.66
	5	2.71	2.84	2.88	2.83	2.62
	10	3.74	3.94	4.03	3.96	3.67
	15	4.47	4.74	4.87	4.80	4.46
	20	5.04	5.38	5.55	5.49	5.11
	25	5.49	5.91	6.12	6.07	5.67
EVR 15	2	2.67	2.79	2.83	2.77	2.56
	5	4.17	4.37	4.44	4.36	4.03
	10	5.76	6.07	6.20	6.10	5.66
	15	6.89	7.30	7.50	7.39	6.87
	20	7.76	8.29	8.54	8.45	7.87
	25	8.46	9.10	9.42	9.35	8.73
EVR 18	2	3.50	3.65	3.71	3.63	3.35
	5	5.46	5.72	5.81	5.70	5.28
	10	7.54	7.95	8.12	7.98	7.40
	15	9.01	9.56	9.81	9.68	9.00
	20	10.16	10.85	11.18	11.06	10.31
	25	11.07	11.91	12.33	12.24	11.43
EVR 20	2	5.55	5.79	5.88	5.75	5.32
	5	8.66	9.07	9.22	9.04	8.37
	10	11.96	12.60	12.87	12.66	11.74
	15	14.30	15.17	15.56	15.35	14.27
	20	16.11	17.20	17.73	17.55	16.35
	25	17.56	18.89	19.56	19.42	18.14
EVR 22	2	6.33	6.61	6.70	6.56	6.06
	5	9.87	10.34	10.52	10.31	9.54
	10	13.64	14.37	14.68	14.44	13.39
	15	16.31	17.30	17.75	17.51	16.28
	20	18.37	19.62	20.22	20.01	18.65
	25	20.03	21.54	22.31	22.15	20.68

Correction factors

The table values refer to hot gas capacity and are given as a function of condensing temperature t_c and pressure drop Δp across the valve.

Capacities are based on:
Hot gas temperature = $t_c + 40^\circ\text{F}$
Subcooling = 10°F
Evaporating temperature = 40°F
Superheat = 0°F

For each additional 10°F of superheat above 40°F , the table capacities must be reduced by 1%.

When the valve is used in a hot gas defrost circuit, evaporator temperature affects the capacity. When the evaporator temperature differs from 40°F , adjust the table capacities by multiplying them by the appropriate correction factor found in the following table.

Metric conversions

1 psi = 0.07 bar
 $\frac{5}{9}(t_1 - 32) = t_2$
1 TR = 3.5 kW

Correction factors for t_h and t_e

t_e [$^\circ\text{F}$]	-40	-20	0	20	40	50
Factor	1.18	1.14	1.09	1.04	1	0.97

Data sheet | Solenoid valve, types EVR 2 - EVR 40 Version 2

**Extended capacity
Hot gas**

Correction factors

The table values refer to hot gas capacity and are given as a function of condensing temperature t_c and pressure drop Δp across the valve.

Capacities are based on:
Hot gas temperature = $t_c + 40$ °F
Subcooling = 10 °F

Evaporating temperature = 40 °F

Superheat = 0 °F

For each additional 10 °F of superheat above 40 °F, the table capacities must be reduced by 1%.

When the valve is used in a hot gas defrost circuit, evaporator temperature affects the capacity. When the evaporator temperature differs from 40 °F, adjust the table capacities by multiplying them by the appropriate correction factor found in the following table.

Metric conversions

1 psi = 0.07 bar

$\frac{5}{9}(t_1 \text{ °F} - 32) = t_2 \text{ °C}$

1 TR = 3.5 kW

Type	Pressure drop across valve Δp [psi]	Hot gas capacity Q_h [TR], Evaporating temp. $t_e = 40$ °F, Hot gas temp. $t_h = t_c + 40$ °F, Subcooling $\Delta t_{sub} = 10$ °F				
		Condensing temperature t_c [°F]				
		60	80	100	120	140
R404A/R507 (continued)						
EVR 25	5	14.17	14.84	15.10	14.80	13.70
	10	19.58	20.63	21.08	20.73	19.23
	15	23.41	24.83	25.48	25.13	23.37
	20	26.37	28.16	29.03	28.73	26.77
	25	28.75	30.92	32.02	31.79	29.69
EVR 32	5	24.22	25.36	25.80	25.30	23.41
	10	33.46	35.26	36.02	35.42	32.86
	15	40.00	42.43	43.54	42.95	39.93
	20	45.07	48.13	49.61	49.10	45.74
	25	49.13	52.84	54.72	54.33	50.74
EVR 40	5	35.03	36.69	37.32	36.60	33.87
	10	48.39	51.00	52.10	51.24	47.53
	15	57.86	61.38	62.98	62.13	57.76
	20	65.19	69.62	71.76	71.02	66.17
	25	71.07	76.43	79.16	78.59	73.39

Correction factors for t_h and t_e

t_e [°F]	-40	-20	0	20	40	50
Factor	1.18	1.14	1.09	1.04	1	0.97

**Extended capacity
Hot gas**

Type	Pressure drop across valve Δp [psi]	Hot gas capacity Q_h [TR], Evaporating temp. $t_e = 40^\circ\text{F}$, Hot gas temp. $t_h = t_c + 40^\circ\text{F}$, Subcooling $\Delta t_{\text{sub}} = 10^\circ\text{F}$				
		Condensing temperature t_c [$^\circ\text{F}$]				
		60	80	100	120	140
R410A						
EVR 2	2	0.19	0.20	0.21	0.21	0.21
	5	0.29	0.31	0.33	0.33	0.33
	10	0.41	0.44	0.46	0.47	0.46
	15	0.49	0.53	0.56	0.57	0.56
	20	0.55	0.60	0.64	0.66	0.65
	25	0.61	0.66	0.71	0.73	0.72
EVR 3	2	0.34	0.36	0.38	0.38	0.38
	5	0.52	0.56	0.59	0.60	0.59
	10	0.73	0.79	0.83	0.85	0.83
	15	0.88	0.95	1.00	1.03	1.01
	20	1.00	1.08	1.15	1.18	1.16
	25	1.09	1.20	1.27	1.31	1.29
EVR 4	2	0.84	0.90	0.95	0.96	0.94
	5	1.32	1.42	1.49	1.52	1.49
	10	1.84	1.98	2.08	2.13	2.09
	15	2.21	2.39	2.53	2.59	2.55
	20	2.51	2.73	2.89	2.97	2.93
	25	2.76	3.01	3.20	3.30	3.25
EVR 6	2	1.11	1.18	1.24	1.26	1.24
	5	1.73	1.85	1.94	1.99	1.95
	10	2.41	2.59	2.72	2.79	2.74
	15	2.90	3.13	3.31	3.39	3.34
	20	3.29	3.57	3.78	3.89	3.83
	25	3.61	3.94	4.19	4.31	4.26
EVR 8	2	1.32	1.41	1.47	1.50	1.47
	5	2.06	2.21	2.32	2.36	2.32
	10	2.86	3.09	3.25	3.32	3.26
	15	3.45	3.73	3.94	4.04	3.97
	20	3.91	4.25	4.50	4.63	4.56
	25	4.30	4.70	4.99	5.14	5.07

Correction factors

The table values refer to hot gas capacity and are given as a function of condensing temperature t_c and pressure drop Δp across the valve.

Capacities are based on:
Hot gas temperature = $t_c + 40^\circ\text{F}$
Subcooling = 10°F
Evaporating temperature = 40°F
Superheat = 0°F

For each additional 10°F of superheat above 40°F , the table capacities must be reduced by 1%.

When the valve is used in a hot gas defrost circuit, evaporator temperature affects the capacity. When the evaporator temperature differs from 40°F , adjust the table capacities by multiplying them by the appropriate correction factor found in the following table.

Metric conversions

1 psi = 0.07 bar
 $5/9(t_1^\circ\text{F} - 32) = t_2^\circ\text{C}$
1 TR = 3.5 kW

Correction factors for t_h and t_e

t_e [$^\circ\text{F}$]	-40	-20	0	20	40	50
Factor	1.18	1.14	1.09	1.04	1	0.97

**Extended capacity
Hot gas**

Type	Pressure drop across valve Δp [psi]	Hot gas capacity Q_h [TR], Evaporating temp. $t_e = 40$ °F, Hot gas temp. $t_h = t_c + 40$ °F, Subcooling $\Delta t_{sub} = 10$ °F				
		Condensing temperature t_c [°F]				
		60	80	100	120	140
R410A (continued)						
EVR 10	2	2.32	2.48	2.60	2.65	2.60
	5	3.63	3.90	4.09	4.17	4.09
	10	5.05	5.44	5.73	5.86	5.76
	15	6.08	6.58	6.95	7.12	7.01
	20	6.90	7.51	7.95	8.17	8.05
	25	7.58	8.28	8.80	9.06	8.95
EVR 15	2	3.58	3.82	4.00	4.08	4.00
	5	5.60	6.00	6.29	6.43	6.30
	10	7.78	8.38	8.82	9.02	8.87
	15	9.37	10.14	10.70	10.97	10.80
	20	10.63	11.56	12.24	12.58	12.40
	25	11.68	12.76	13.55	13.96	13.79
EVR 18	2	4.68	5.01	5.24	5.34	5.24
	5	7.33	7.86	8.24	8.41	8.25
	10	10.19	10.97	11.54	11.81	11.61
	15	12.27	13.27	14.00	14.36	14.14
	20	13.92	15.13	16.02	16.46	16.23
	25	15.29	16.70	17.74	18.27	18.05
EVR 20	2	7.43	7.94	8.31	8.47	8.31
	5	11.62	12.46	13.07	13.34	13.09
	10	16.16	17.41	18.31	18.73	18.41
	15	19.46	21.05	22.21	22.78	22.42
	20	22.08	24.00	25.41	26.12	25.75
	25	24.25	26.49	28.14	28.99	28.62
EVR 22	2	8.47	9.06	9.48	9.66	9.47
	5	13.26	14.21	14.90	15.22	14.93
	10	18.43	19.85	20.88	21.37	21.00
	15	22.19	24.01	25.34	25.98	25.57
	20	25.18	27.37	28.98	29.79	29.36
	25	27.65	30.21	32.09	33.06	32.64

Correction factors

The table values refer to hot gas capacity and are given as a function of condensing temperature t_c and pressure drop Δp across the valve.

Capacities are based on:
Hot gas temperature = $t_c + 40$ °F
Subcooling = 10 °F
Evaporating temperature = 40 °F
Superheat = 0 °F

For each additional 10 °F of superheat above 40 °F, the table capacities must be reduced by 1%.

When the valve is used in a hot gas defrost circuit, evaporator temperature affects the capacity. When the evaporator temperature differs from 40 °F, adjust the table capacities by multiplying them by the appropriate correction factor found in the following table.

Metric conversions

1 psi = 0.07 bar
 $\frac{5}{9}(t_1 \text{ °F} - 32) = t_2 \text{ °C}$
1 TR = 3.5 kW

Correction factors for t_h and t_e

t_e [°F]	-40	-20	0	20	40	50
Factor	1.18	1.14	1.09	1.04	1	0.97

Data sheet | Solenoid valve, types EVR 2 - EVR 40 Version 2

**Extended capacity
Hot gas**

Correction factors

The table values refer to hot gas capacity and are given as a function of condensing temperature t_c and pressure drop Δp across the valve.

Capacities are based on:
Hot gas temperature = $t_c + 40$ °F
Subcooling = 10 °F

Evaporating temperature = 40 °F

Superheat = 0 °F

For each additional 10 °F of superheat above 40 °F, the table capacities must be reduced by 1%.

When the valve is used in a hot gas defrost circuit, evaporator temperature affects the capacity. When the evaporator temperature differs from 40 °F, adjust the table capacities by multiplying them by the appropriate correction factor found in the following table.

Metric conversions

1 psi = 0.07 bar

$\frac{5}{9}(t_1 \text{ °F} - 32) = t_2 \text{ °C}$

1 TR = 3.5 kW

Type	Pressure drop across valve Δp [psi]	Hot gas capacity Q_h [TR], Evaporating temp. $t_e = 40$ °F, Hot gas temp. $t_h = t_c + 40$ °F, Subcooling $\Delta t_{sub} = 10$ °F				
		Condensing temperature t_c [°F]				
		60	80	100	120	140
R410A (continued)						
EVR 25	5	19.03	20.40	21.39	21.84	21.43
	10	26.46	28.50	29.97	30.67	30.14
	15	31.85	34.47	36.37	37.30	36.71
	20	36.14	39.30	41.60	42.76	42.15
	25	39.70	43.37	46.07	47.46	46.86
EVR 32	5	32.52	34.87	36.56	37.33	36.62
	10	45.22	48.70	51.22	52.41	51.50
	15	54.44	58.90	62.15	63.74	62.73
	20	61.77	67.15	71.09	73.07	72.03
	25	67.84	74.12	78.72	81.10	80.08
EVR 40	5	47.04	50.43	52.88	53.99	52.97
	10	65.41	70.44	74.09	75.82	74.50
	15	78.74	85.20	89.90	92.19	90.74
	20	89.35	97.14	102.83	105.69	104.19
	25	98.13	107.21	113.87	117.31	115.83

Correction factors for t_h and t_e

t_e [°F]	-40	-20	0	20	40	50
Factor	1.18	1.14	1.09	1.04	1	0.97

**Extended capacity
Hot gas**

Type	Pressure drop across valve Δp [psi]	Hot gas capacity Q_h [TR], Evaporating temp. $t_e = 40^\circ\text{F}$, Hot gas temp. $t_h = t_c + 40^\circ\text{F}$, Subcooling $\Delta t_{\text{sub}} = 10^\circ\text{F}$				
		Condensing temperature t_c [$^\circ\text{F}$]				
		60	80	100	120	140
R32						
EVR 2	2	0.23	0.25	0.27	0.28	0.29
	5	0.36	0.39	0.42	0.44	0.45
	10	0.50	0.55	0.59	0.62	0.64
	15	0.60	0.66	0.71	0.76	0.78
	20	0.68	0.76	0.82	0.87	0.89
	25	0.75	0.84	0.91	0.96	0.99
EVR 3	2	0.41	0.45	0.48	0.50	0.52
	5	0.65	0.70	0.76	0.79	0.82
	10	0.90	0.99	1.06	1.12	1.15
	15	1.08	1.19	1.29	1.36	1.40
	20	1.23	1.36	1.47	1.56	1.61
	25	1.35	1.50	1.63	1.73	1.79
EVR 4	2	1.04	1.13	1.21	1.27	1.30
	5	1.63	1.77	1.90	2.00	2.06
	10	2.26	2.48	2.67	2.81	2.89
	15	2.73	3.00	3.24	3.42	3.52
	20	3.10	3.43	3.71	3.93	4.05
	25	3.41	3.79	4.11	4.36	4.50
EVR 6	2	1.36	1.48	1.58	1.66	1.71
	5	2.13	2.32	2.49	2.62	2.69
	10	2.96	3.25	3.49	3.68	3.79
	15	3.57	3.93	4.24	4.48	4.61
	20	4.06	4.49	4.85	5.14	5.30
	25	4.46	4.96	5.38	5.71	5.89
EVR 8	2	1.62	1.76	1.89	1.98	2.03
	5	2.53	2.77	2.97	3.12	3.20
	10	3.53	3.87	4.16	4.38	4.51
	15	4.25	4.68	5.05	5.34	5.49
	20	4.83	5.34	5.78	6.12	6.31
	25	5.32	5.91	6.41	6.80	7.02

Correction factors

The table values refer to hot gas capacity and are given as a function of condensing temperature t_c and pressure drop Δp across the valve.

Capacities are based on:
Hot gas temperature = $t_c + 40^\circ\text{F}$
Subcooling = 10°F
Evaporating temperature = 40°F
Superheat = 0°F

For each additional 10°F of superheat above 40°F , the table capacities must be reduced by 1%.

When the valve is used in a hot gas defrost circuit, evaporator temperature affects the capacity. When the evaporator temperature differs from 40°F , adjust the table capacities by multiplying them by the appropriate correction factor found in the following table.

Metric conversions

1 psi = 0.07 bar
 $\frac{5}{9}(t_1 - 32) = t_2$ °C
1 TR = 3.5 kW

Correction factors for t_h and t_e

t_e [$^\circ\text{F}$]	-40	-20	0	20	40	50
Factor	1.18	1.14	1.09	1.04	1	0.97

**Extended capacity
Hot gas**

Type	Pressure drop across valve Δp [psi]	Hot gas capacity Q_h [TR], Evaporating temp. $t_e = 40^\circ\text{F}$, Hot gas temp. $t_h = t_c + 40^\circ\text{F}$, Subcooling $\Delta t_{\text{sub}} = 10^\circ\text{F}$				
		Condensing temperature t_c [$^\circ\text{F}$]				
		60	80	100	120	140
R32 (continued)						
EVR 10	2	2.85	3.11	3.33	3.50	3.59
	5	4.47	4.88	5.23	5.51	5.65
	10	6.22	6.82	7.34	7.74	7.95
	15	7.50	8.26	8.91	9.41	9.69
	20	8.53	9.43	10.20	10.80	11.14
	25	9.38	10.42	11.31	11.99	12.39
EVR 15	2	4.39	4.78	5.12	5.38	5.52
	5	6.88	7.51	8.06	8.48	8.71
	10	9.59	10.51	11.30	11.91	12.25
	15	11.56	12.72	13.72	14.50	14.93
	20	13.13	14.52	15.71	16.63	17.15
	25	14.45	16.04	17.41	18.47	19.08
EVR 18	2	5.75	6.26	6.71	7.05	7.23
	5	9.01	9.84	10.55	11.10	11.40
	10	12.55	13.75	14.79	15.60	16.04
	15	15.13	16.65	17.96	18.98	19.54
	20	17.19	19.01	20.56	21.77	22.45
	25	18.91	21.00	22.79	24.18	24.97
EVR 20	2	9.12	9.94	10.64	11.18	11.47
	5	14.29	15.60	16.73	17.61	18.08
	10	19.90	21.82	23.47	24.74	25.44
	15	23.99	26.42	28.49	30.10	31.00
	20	27.27	30.15	32.62	34.53	35.61
	25	29.99	33.32	36.15	38.35	39.61
EVR 22	2	10.40	11.33	12.13	12.75	13.08
	5	16.30	17.80	19.09	20.08	20.62
	10	22.70	24.88	26.76	28.21	29.01
	15	27.37	30.13	32.50	34.33	35.35
	20	31.10	34.39	37.20	39.38	40.61
	25	34.21	38.00	41.23	43.74	45.17

Correction factors

The table values refer to hot gas capacity and are given as a function of condensing temperature t_c and pressure drop Δp across the valve.

Capacities are based on:
Hot gas temperature = $t_c + 40^\circ\text{F}$
Subcooling = 10°F
Evaporating temperature = 40°F
Superheat = 0°F

For each additional 10°F of superheat above 40°F , the table capacities must be reduced by 1%.

When the valve is used in a hot gas defrost circuit, evaporator temperature affects the capacity. When the evaporator temperature differs from 40°F , adjust the table capacities by multiplying them by the appropriate correction factor found in the following table.

Metric conversions

1 psi = 0.07 bar
 $\frac{5}{9}(t_1 - 32) = t_2$
1 TR = 3.5 kW

Correction factors for t_h and t_e

t_e [$^\circ\text{F}$]	-40	-20	0	20	40	50
Factor	1.18	1.14	1.09	1.04	1	0.97

**Extended capacity
Hot gas**

Type	Pressure drop across valve Δp [psi]	Hot gas capacity Q_h [TR], Evaporating temp. $t_e = 40^\circ\text{F}$, Hot gas temp. $t_h = t_c + 40^\circ\text{F}$, Subcooling $\Delta t_{\text{sub}} = 10^\circ\text{F}$				
		Condensing temperature t_c [$^\circ\text{F}$]				
		60	80	100	120	140
R290						
EVR 2	2	0.18	0.19	0.20	0.20	0.20
	5	0.28	0.30	0.32	0.32	0.32
	10	0.39	0.42	0.44	0.45	0.45
	15	0.46	0.50	0.53	0.54	0.54
	20	0.52	0.56	0.60	0.62	0.62
	25	0.56	0.62	0.66	0.68	0.68
EVR 3	2	0.33	0.35	0.36	0.37	0.36
	5	0.51	0.54	0.57	0.58	0.57
	10	0.70	0.75	0.79	0.81	0.80
	15	0.83	0.90	0.95	0.98	0.97
	20	0.93	1.02	1.08	1.11	1.11
	25	1.01	1.11	1.18	1.23	1.23
EVR 4	2	0.83	0.88	0.91	0.93	0.92
	5	1.29	1.37	1.43	1.46	1.44
	10	1.77	1.90	1.99	2.03	2.02
	15	2.10	2.27	2.39	2.46	2.45
	20	2.34	2.56	2.72	2.80	2.79
	25	2.53	2.79	2.98	3.09	3.09
EVR 6	2	1.09	1.15	1.20	1.22	1.20
	5	1.69	1.80	1.87	1.91	1.89
	10	2.31	2.48	2.60	2.66	2.64
	15	2.74	2.97	3.13	3.22	3.20
	20	3.07	3.35	3.55	3.66	3.66
	25	3.31	3.66	3.90	4.04	4.05
EVR 8	2	1.29	1.37	1.42	1.45	1.43
	5	2.01	2.14	2.23	2.27	2.25
	10	2.75	2.96	3.10	3.17	3.15
	15	3.27	3.54	3.73	3.83	3.81
	20	3.65	3.99	4.23	4.36	4.36
	25	3.95	4.36	4.65	4.81	4.82

Correction factors

The table values refer to hot gas capacity and are given as a function of condensing temperature t_c and pressure drop Δp across the valve.

Capacities are based on:
Hot gas temperature = $t_c + 40^\circ\text{F}$
Subcooling = 10°F
Evaporating temperature = 40°F
Superheat = 0°F

For each additional 10°F of superheat above 40°F , the table capacities must be reduced by 1%.

When the valve is used in a hot gas defrost circuit, evaporator temperature affects the capacity. When the evaporator temperature differs from 40°F , adjust the table capacities by multiplying them by the appropriate correction factor found in the following table.

Metric conversions

1 psi = 0.07 bar
 $5/9(t_1 - 32) = t_2$
1 TR = 3.5 kW

Correction factors for t_h and t_e

t_e [$^\circ\text{F}$]	-40	-20	0	20	40	50
Factor	1.18	1.14	1.09	1.04	1	0.97

**Extended capacity
Hot gas**

Type	Pressure drop across valve Δp [psi]	Hot gas capacity Q_h [TR], Evaporating temp. $t_e = 40^\circ\text{F}$, Hot gas temp. $t_h = t_c + 40^\circ\text{F}$, Subcooling $\Delta t_{\text{sub}} = 10^\circ\text{F}$				
		Condensing temperature t_c [$^\circ\text{F}$]				
		60	80	100	120	140
R290 (continued)						
EVR 10	2	2.28	2.42	2.51	2.55	2.52
	5	3.54	3.77	3.93	4.01	3.97
	10	4.86	5.22	5.47	5.59	5.55
	15	5.77	6.25	6.58	6.76	6.73
	20	6.44	7.04	7.47	7.69	7.68
	25	6.97	7.68	8.20	8.49	8.50
EVR 15	2	3.51	3.73	3.87	3.93	3.89
	5	5.46	5.81	6.06	6.17	6.11
	10	7.48	8.04	8.42	8.61	8.55
	15	8.88	9.62	10.14	10.40	10.36
	20	9.92	10.85	11.50	11.85	11.83
	25	10.73	11.84	12.63	13.07	13.09
EVR 18	2	4.60	4.88	5.07	5.15	5.09
	5	7.14	7.61	7.93	8.08	7.99
	10	9.79	10.52	11.03	11.27	11.19
	15	11.62	12.59	13.27	13.62	13.56
	20	12.99	14.20	15.05	15.51	15.49
	25	14.04	15.49	16.53	17.11	17.13
EVR 20	2	7.29	7.74	8.04	8.17	8.07
	5	11.33	12.07	12.58	12.81	12.68
	10	15.54	16.69	17.49	17.88	17.75
	15	18.44	19.97	21.05	21.60	21.51
	20	20.61	22.52	23.88	24.61	24.57
	25	22.27	24.57	26.22	27.13	27.18
EVR 22	2	8.32	8.82	9.17	9.31	9.20
	5	12.92	13.77	14.35	14.61	14.46
	10	17.72	19.03	19.95	20.39	20.24
	15	21.03	22.78	24.01	24.64	24.53
	20	23.50	25.68	27.23	28.06	28.02
	25	25.40	28.03	29.90	30.95	31.00

Correction factors

The table values refer to hot gas capacity and are given as a function of condensing temperature t_c and pressure drop Δp across the valve.

Capacities are based on:
Hot gas temperature = $t_c + 40^\circ\text{F}$
Subcooling = 10°F
Evaporating temperature = 40°F
Superheat = 0°F

For each additional 10°F of superheat above 40°F , the table capacities must be reduced by 1%.

When the valve is used in a hot gas defrost circuit, evaporator temperature affects the capacity. When the evaporator temperature differs from 40°F , adjust the table capacities by multiplying them by the appropriate correction factor found in the following table.

Metric conversions

1 psi = 0.07 bar
 $\frac{5}{9}(t_1 - 32) = t_2$
1 TR = 3.5 kW

Correction factors for t_h and t_e

t_e [$^\circ\text{F}$]	-40	-20	0	20	40	50
Factor	1.18	1.14	1.09	1.04	1	0.97

**Extended capacity
Hot gas**

Type	Pressure drop across valve Δp [psi]	Hot gas capacity Q_h [TR], Evaporating temp. $t_e = 40^\circ\text{F}$, Hot gas temp. $t_h = t_c + 40^\circ\text{F}$, Subcooling $\Delta t_{\text{sub}} = 10^\circ\text{F}$				
		Condensing temperature t_c [$^\circ\text{F}$]				
		60	80	100	120	140
R600a						
EVR 2	2	0.11	0.12	0.13	0.14	0.14
	5	0.17	0.19	0.20	0.21	0.22
	10	0.22	0.25	0.27	0.29	0.30
	15	0.24	0.29	0.32	0.34	0.35
	20	0.25	0.31	0.35	0.38	0.40
	25	0.25	0.31	0.37	0.41	0.43
EVR 3	2	0.21	0.22	0.24	0.25	0.25
	5	0.31	0.34	0.37	0.38	0.39
	10	0.39	0.45	0.49	0.52	0.54
	15	0.43	0.51	0.57	0.62	0.64
	20	0.44	0.55	0.63	0.69	0.72
	25	0.44	0.56	0.67	0.74	0.78
EVR 4	2	0.52	0.56	0.60	0.62	0.63
	5	0.78	0.86	0.92	0.96	0.98
	10	0.99	1.14	1.24	1.32	1.35
	15	1.09	1.29	1.45	1.55	1.61
	20	1.12	1.38	1.59	1.73	1.81
	25	1.12	1.42	1.68	1.86	1.96
EVR 6	2	0.68	0.74	0.78	0.81	0.82
	5	1.01	1.12	1.21	1.26	1.28
	10	1.30	1.49	1.63	1.72	1.77
	15	1.43	1.69	1.89	2.03	2.10
	20	1.46	1.81	2.07	2.26	2.36
	25	1.46	1.86	2.19	2.43	2.57
EVR 8	2	0.81	0.88	0.93	0.97	0.98
	5	1.21	1.34	1.44	1.50	1.53
	10	1.55	1.77	1.94	2.05	2.10
	15	1.70	2.02	2.26	2.42	2.51
	20	1.74	2.16	2.47	2.69	2.81
	25	1.74	2.22	2.61	2.89	3.06

Correction factors

The table values refer to hot gas capacity and are given as a function of condensing temperature t_c and pressure drop Δp across the valve.

Capacities are based on:
Hot gas temperature = $t_c + 40^\circ\text{F}$
Subcooling = 10°F
Evaporating temperature = 40°F
Superheat = 0°F

For each additional 10°F of superheat above 40°F , the table capacities must be reduced by 1%.

When the valve is used in a hot gas defrost circuit, evaporator temperature affects the capacity. When the evaporator temperature differs from 40°F , adjust the table capacities by multiplying them by the appropriate correction factor found in the following table.

Metric conversions

1 psi = 0.07 bar
 $\frac{5}{9}(t_1 - 32) = t_2$ °C
1 TR = 3.5 kW

Correction factors for t_h and t_e

t_e [$^\circ\text{F}$]	-40	-20	0	20	40	50
Factor	1.18	1.14	1.09	1.04	1	0.97

**Extended capacity
Hot gas**

Type	Pressure drop across valve Δp [psi]	Hot gas capacity Q_h [TR], Evaporating temp. $t_e = 40$ °F, Hot gas temp. $t_h = t_c + 40$ °F, Subcooling $\Delta t_{sub} = 10$ °F				
		Condensing temperature t_c [°F]				
		60	80	100	120	140
R600a (continued)						
EVR 10	2	1.42	1.55	1.65	1.71	1.73
	5	2.13	2.36	2.54	2.65	2.70
	10	2.73	3.12	3.42	3.62	3.71
	15	3.01	3.56	3.98	4.27	4.42
	20	3.08	3.80	4.36	4.75	4.96
	25	3.08	3.91	4.61	5.10	5.39
EVR 15	2	2.19	2.39	2.54	2.64	2.67
	5	3.28	3.64	3.90	4.08	4.15
	10	4.21	4.81	5.26	5.57	5.72
	15	4.63	5.48	6.13	6.58	6.81
	20	4.74	5.86	6.71	7.31	7.65
	25	4.74	6.02	7.10	7.86	8.30
EVR 18	2	2.87	3.13	3.32	3.45	3.49
	5	4.30	4.76	5.11	5.34	5.44
	10	5.51	6.29	6.89	7.29	7.48
	15	6.06	7.17	8.03	8.61	8.92
	20	6.20	7.67	8.79	9.57	10.01
	25	6.20	7.88	9.29	10.29	10.87
EVR 20	2	4.55	4.96	5.27	5.47	5.54
	5	6.82	7.55	8.11	8.48	8.62
	10	8.75	9.98	10.93	11.57	11.87
	15	9.61	11.38	12.73	13.66	14.14
	20	9.84	12.16	13.94	15.18	15.88
	25	9.84	12.51	14.74	16.32	17.24
EVR 22	2	5.19	5.66	6.01	6.24	6.32
	5	7.78	8.61	9.25	9.67	9.83
	10	9.97	11.39	12.47	13.19	13.54
	15	10.97	12.98	14.52	15.58	16.13
	20	11.22	13.87	15.90	17.32	18.11
	25	11.22	14.26	16.81	18.61	19.66

Correction factors

The table values refer to hot gas capacity and are given as a function of condensing temperature t_c and pressure drop Δp across the valve.

Capacities are based on:
Hot gas temperature = $t_c + 40$ °F
Subcooling = 10 °F
Evaporating temperature = 40 °F
Superheat = 0 °F

For each additional 10 °F of superheat above 40 °F, the table capacities must be reduced by 1%.

When the valve is used in a hot gas defrost circuit, evaporator temperature affects the capacity. When the evaporator temperature differs from 40 °F, adjust the table capacities by multiplying them by the appropriate correction factor found in the following table.

Metric conversions

1 psi = 0.07 bar
 $\frac{5}{9}(t_1 - 32) = t_2$ °C
1 TR = 3.5 kW

Correction factors for t_h and t_e

t_e [°F]	-40	-20	0	20	40	50
Factor	1.18	1.14	1.09	1.04	1	0.97

**Extended capacity
Hot gas**

Type	Condensing temperature t_c [°F]	Hot gas capacity Q_h [lb/min] at pressure drop across valve Δp [psi]							
		Hot gas temperature t_h 140 °F							
		5	15	25	40	60	80	100	120
R22/R407C									
EVR 2	80	0.62	1.04	1.28	1.52	1.70	1.76	1.77	1.77
	100	0.74	1.25	1.56	1.88	2.16	2.32	2.40	2.42
	120	0.88	1.49	1.88	2.30	2.68	2.94	3.11	3.22
EVR 3	80	1.12	1.87	2.31	2.74	3.05	3.18	3.18	3.18
	100	1.33	2.24	2.81	3.39	3.88	4.17	4.31	4.35
	120	1.59	2.69	3.39	4.14	4.83	5.29	5.60	5.79
EVR 4	80	2.82	4.70	5.82	6.90	7.69	8.00	8.02	8.02
	100	3.36	5.65	7.07	8.53	9.77	10.50	10.87	10.95
	120	4.00	6.77	8.54	10.43	12.16	13.33	14.10	14.58
EVR 6	80	3.70	6.15	7.62	9.03	10.06	10.47	10.50	10.50
	100	4.40	7.39	9.26	11.17	12.79	13.74	14.22	14.33
	120	5.23	8.86	11.18	13.65	15.91	17.44	18.46	19.08
EVR 8	80	4.40	7.33	9.08	10.75	11.98	12.47	12.50	12.50
	100	5.24	8.81	11.03	13.30	15.23	16.37	16.94	17.07
	120	6.23	10.56	13.32	16.26	18.95	20.77	21.98	22.72
EVR 10	80	7.77	12.93	16.01	18.97	21.14	21.99	22.05	22.05
	100	9.24	15.53	19.45	23.46	26.87	28.88	29.88	30.11
	120	11.00	18.62	23.50	28.68	33.43	36.64	38.78	40.08
EVR 15	80	11.96	19.91	24.66	29.22	32.56	33.87	33.96	33.96
	100	14.23	23.92	29.96	36.14	41.39	44.48	46.02	46.37
	120	16.94	28.68	36.19	44.17	51.49	56.44	59.73	61.73
EVR 18	80	15.66	26.06	32.28	38.25	42.62	44.34	44.46	44.46
	100	18.62	31.32	39.22	47.31	54.18	58.22	60.24	60.70
	120	22.17	37.55	47.37	57.82	67.40	73.88	78.18	80.81
EVR 20	80	24.83	41.34	51.21	60.67	67.61	70.33	70.52	70.52
	100	29.54	49.68	62.21	75.04	85.94	92.35	95.56	96.29
	120	35.17	59.56	75.14	91.72	106.91	117.18	124.01	128.18
EVR 22	80	28.32	47.15	58.40	69.19	77.11	80.21	80.43	80.43
	100	33.69	56.65	70.95	85.58	98.01	105.32	108.98	109.81
	120	40.11	67.92	85.69	104.60	121.93	133.65	141.43	146.19

Correction factors

The table values refer to hot gas capacity and are given as a function of condensing temperature t_c and pressure drop Δp across the valve.

Capacities are based on:
Hot gas temperature = 140 °F
Subcooling = 10 °F
Evaporating temperature = 40 °F
Superheat = 0 °F

For each additional 10 °F of superheat above 40 °F, the table capacities must be reduced by 1%.

When the valve is used in a hot gas defrost circuit, evaporator temperature affects the capacity. When the evaporator temperature differs from 40 °F, adjust the table capacities by multiplying them by the appropriate correction factor found in the following table.

Metric conversions

1 psi = 0.07 bar
 $\frac{5}{9}(t_1 \text{ °F} - 32) = t_2 \text{ °C}$
1 TR = 3.5 kW

Correction factors for t_h and t_e

t_e [°F]	-40	-20	0	20	40	50
Factor	1.18	1.14	1.09	1.04	1	0.97

**Extended capacity
Hot gas**
Correction factors

The table values refer to hot gas capacity and are given as a function of condensing temperature t_c and pressure drop Δp across the valve.

Capacities are based on:
Hot gas temperature = 140 °F
Subcooling = 10 °F

Evaporating temperature = 40 °F

Superheat = 0 °F

For each additional 10 °F of superheat above 40 °F, the table capacities must be reduced by 1%.

When the valve is used in a hot gas defrost circuit, evaporator temperature affects the capacity. When the evaporator temperature differs from 40 °F, adjust the table capacities by multiplying them by the appropriate correction factor found in the following table.

Metric conversions

1 psi = 0.07 bar

$\frac{5}{9}(t_1 \text{ °F} - 32) = t_2 \text{ °C}$

1 TR = 3.5 kW

Type	Condensing temperature t_c [°F]	Hot gas capacity Q_h [lb/min] at pressure drop across valve Δp [psi]							
		Hot gas temperature t_h 140 °F							
		5	15	25	40	60	80	100	120
R22/R407C (continued)									
EVR 25	80	40.66	67.68	83.83	99.33	110.68	115.15	115.46	115.46
	100	48.36	81.33	101.84	122.84	140.69	151.19	156.44	157.64
	120	57.57	97.50	123.01	150.16	175.02	191.85	203.03	209.85
EVR 32	80	69.48	115.65	143.26	169.74	189.15	196.77	197.30	197.30
	100	82.64	138.98	174.03	209.93	240.43	258.37	267.34	269.38
	120	98.39	166.62	210.21	256.60	299.09	327.84	346.95	358.61
EVR 40	80	100.50	167.29	207.23	245.53	273.60	284.63	285.40	285.40
	100	119.55	201.03	251.74	303.66	347.78	373.73	386.71	389.66
	120	142.32	241.01	304.06	371.17	432.64	474.23	501.87	518.73

Correction factors for t_h and t_e

t_e [°F]	-40	-20	0	20	40	50
Factor	1.18	1.14	1.09	1.04	1	0.97

**Extended capacity
Hot gas**

Type	Condensing temperature t_c [°F]	Hot gas capacity Q_h [lb/min] at pressure drop across valve Δp [psi]							
		Hot gas temperature t_h 140 °F							
		5	15	25	40	60	80	100	120
R134a									
EVR 2	80	0.53	0.86	1.03	1.16	1.18	1.18	1.18	–
	100	0.64	1.06	1.30	1.51	1.64	1.66	1.66	1.66
	120	0.77	1.29	1.61	1.92	2.16	2.28	2.30	2.30
EVR 3	80	0.95	1.54	1.85	2.08	2.13	2.13	2.13	–
	100	1.15	1.90	2.34	2.72	2.96	2.99	2.99	2.99
	120	1.39	2.33	2.89	3.45	3.89	4.10	4.15	4.15
EVR 4	80	2.40	3.89	4.67	5.24	5.37	5.37	5.37	–
	100	2.91	4.79	5.88	6.86	7.45	7.53	7.53	7.53
	120	3.50	5.86	7.29	8.69	9.79	10.32	10.45	10.45
EVR 6	80	3.14	5.09	6.11	6.86	7.03	7.03	7.03	–
	100	3.80	6.27	7.70	8.97	9.75	9.86	9.86	9.86
	120	4.59	7.67	9.54	11.38	12.82	13.51	13.67	13.67
EVR 8	80	3.74	6.06	7.28	8.17	8.37	8.37	8.37	–
	100	4.53	7.47	9.17	10.69	11.61	11.74	11.74	11.74
	120	5.46	9.13	11.36	13.55	15.27	16.09	16.28	16.28
EVR 10	80	6.61	10.70	12.84	14.41	14.76	14.76	14.76	–
	100	7.99	13.18	16.17	18.86	20.48	20.71	20.71	20.71
	120	9.64	16.11	20.04	23.91	26.93	28.39	28.73	28.73
EVR 15	80	10.17	16.47	19.78	22.20	22.74	22.74	22.74	–
	100	12.30	20.30	24.91	29.04	31.53	31.89	31.89	31.89
	120	14.84	24.80	30.86	36.82	41.48	43.73	44.24	44.24
EVR 18	80	13.32	21.56	25.89	29.06	29.76	29.76	29.76	–
	100	16.11	26.58	32.61	38.01	41.28	41.75	41.75	41.75
	120	19.43	32.47	40.39	48.20	54.30	57.24	57.92	57.92
EVR 20	80	21.13	34.20	41.07	46.09	47.21	47.21	47.21	–
	100	25.55	42.16	51.72	60.30	65.48	66.23	66.23	66.23
	120	30.82	51.50	64.07	76.45	86.13	90.79	91.87	91.87
EVR 22	80	24.09	39.01	46.84	52.57	53.85	53.85	53.85	–
	100	29.14	48.08	58.99	68.77	74.68	75.53	75.53	75.53
	120	35.15	58.74	73.07	87.19	98.23	103.55	104.77	104.77

Correction factors

The table values refer to hot gas capacity and are given as a function of condensing temperature t_c and pressure drop Δp across the valve.

Capacities are based on:
Hot gas temperature = 140 °F
Subcooling = 10 °F
Evaporating temperature = 40 °F
Superheat = 0 °F

For each additional 10 °F of superheat above 40 °F, the table capacities must be reduced by 1%.

When the valve is used in a hot gas defrost circuit, evaporator temperature affects the capacity. When the evaporator temperature differs from 40 °F, adjust the table capacities by multiplying them by the appropriate correction factor found in the following table.

Metric conversions

1 psi = 0.07 bar
 $\frac{5}{9}(t_1 \text{ °F} - 32) = t_2 \text{ °C}$
1 TR = 3.5 kW

Correction factors for t_h and t_e

t_e [°F]	-40	-20	0	20	40	50
Factor	1.18	1.14	1.09	1.04	1	0.97

**Extended capacity
Hot gas**
Correction factors

The table values refer to hot gas capacity and are given as a function of condensing temperature t_c and pressure drop Δp across the valve.

Capacities are based on:
Hot gas temperature = 140 °F
Subcooling = 10 °F

Evaporating temperature = 40 °F

Superheat = 0 °F

For each additional 10 °F of superheat above 40 °F, the table capacities must be reduced by 1%.

When the valve is used in a hot gas defrost circuit, evaporator temperature affects the capacity. When the evaporator temperature differs from 40 °F, adjust the table capacities by multiplying them by the appropriate correction factor found in the following table.

Metric conversions

1 psi = 0.07 bar

$\frac{5}{9}(t_1 \text{ °F} - 32) = t_2 \text{ °C}$

1 TR = 3.5 kW

Type	Condensing temperature t_c [°F]	Hot gas capacity Q_h [lb/min] at pressure drop across valve Δp [psi]							
		Hot gas temperature t_h 140 °F							
		5	15	25	40	60	80	100	120
R134a (continued)									
EVR 25	80	34.59	55.99	67.23	75.46	77.29	77.29	77.29	–
	100	41.83	69.02	84.68	98.72	107.20	108.42	108.42	108.42
	120	50.45	84.32	104.89	125.16	141.00	148.64	150.40	150.40
EVR 32	80	59.10	95.68	114.89	128.95	132.09	132.09	132.09	–
	100	71.48	117.94	144.71	168.70	183.19	185.28	185.28	185.28
	120	86.22	144.09	179.25	213.88	240.96	254.01	257.02	257.02
EVR 40	80	85.49	138.41	166.19	186.52	191.06	191.06	191.06	–
	100	103.39	170.61	209.32	244.02	264.98	268.00	268.00	268.00
	120	124.72	208.43	259.28	309.38	348.55	367.42	371.77	371.77

Correction factors for t_h and t_e

t_e [°F]	-40	-20	0	20	40	50
Factor	1.18	1.14	1.09	1.04	1	0.97

**Extended capacity
Hot gas**

Type	Condensing temperature t_c [°F]	Hot gas capacity Q_h [lb/min] at pressure drop across valve Δp [psi]							
		Hot gas temperature t_h 140 °F							
		5	15	25	40	60	80	100	120
R404A/507									
EVR 2	80	0.75	1.25	1.56	1.86	2.10	2.22	2.26	2.26
	100	0.90	1.51	1.90	2.31	2.66	2.89	3.03	3.09
	120	1.09	1.85	2.34	2.87	3.37	3.71	3.96	4.13
EVR 3	80	1.34	2.25	2.80	3.35	3.78	4.00	4.06	4.06
	100	1.61	2.72	3.42	4.15	4.80	5.21	5.45	5.56
	120	1.96	3.33	4.22	5.17	6.06	6.69	7.13	7.43
EVR 4	80	3.39	5.67	7.05	8.43	9.53	10.07	10.23	10.23
	100	4.06	6.86	8.62	10.46	12.08	13.11	13.72	14.01
	120	4.94	8.39	10.62	13.01	15.26	16.84	17.95	18.71
EVR 6	80	4.43	7.41	9.23	11.04	12.47	13.18	13.39	13.39
	100	5.32	8.97	11.28	13.69	15.81	17.16	17.96	18.33
	120	6.47	10.99	13.90	17.03	19.97	22.04	23.50	24.49
EVR 8	80	5.28	8.83	11.00	13.14	14.85	15.70	15.94	15.94
	100	6.33	10.69	13.43	16.30	18.83	20.44	21.39	21.84
	120	7.71	13.08	16.55	20.29	23.79	26.25	27.99	29.16
EVR 10	80	9.31	15.58	19.40	23.19	26.20	27.70	28.13	28.13
	100	11.17	18.86	23.70	28.76	33.22	36.06	37.74	38.52
	120	13.59	23.08	29.20	35.79	41.97	46.31	49.37	51.45
EVR 15	80	14.34	23.99	29.88	35.71	40.34	42.66	43.32	43.32
	100	17.21	29.04	36.50	44.29	51.17	55.54	58.13	59.33
	120	20.94	35.55	44.97	55.12	64.64	71.32	76.04	79.23
EVR 18	80	18.77	31.41	39.11	46.75	52.81	55.85	56.70	56.70
	100	22.53	38.01	47.78	57.97	66.98	72.70	76.09	77.66
	120	27.41	46.53	58.86	72.15	84.61	93.36	99.53	103.72
EVR 20	80	29.78	49.82	62.04	74.16	83.77	88.59	89.94	89.94
	100	35.73	60.30	75.79	91.96	106.24	115.32	120.69	123.19
	120	43.47	73.81	93.37	114.45	134.21	148.09	157.88	164.52
EVR 22	80	33.96	56.82	70.75	84.57	95.54	101.03	102.58	102.58
	100	40.75	68.77	86.43	104.87	121.17	131.51	137.65	140.50
	120	49.58	84.18	106.48	130.53	153.06	168.90	180.06	187.63

Correction factors

The table values refer to hot gas capacity and are given as a function of condensing temperature t_c and pressure drop Δp across the valve.

Capacities are based on:
Hot gas temperature = 140 °F
Subcooling = 10 °F
Evaporating temperature = 40 °F
Superheat = 0 °F

For each additional 10 °F of superheat above 40 °F, the table capacities must be reduced by 1%.

When the valve is used in a hot gas defrost circuit, evaporator temperature affects the capacity. When the evaporator temperature differs from 40 °F, adjust the table capacities by multiplying them by the appropriate correction factor found in the following table.

Metric conversions

1 psi = 0.07 bar
 $\frac{5}{9}(t_1 \text{ °F} - 32) = t_2 \text{ °C}$
1 TR = 3.5 kW

Correction factors for t_h and t_e

t_e [°F]	-40	-20	0	20	40	50
Factor	1.18	1.14	1.09	1.04	1	0.97

Data sheet | Solenoid valve, types EVR 2 - EVR 40 Version 2

**Extended capacity
Hot gas**

Correction factors

The table values refer to hot gas capacity and are given as a function of condensing temperature t_c and pressure drop Δp across the valve.

Capacities are based on:
Hot gas temperature = 140 °F
Subcooling = 10 °F
Evaporating temperature = 40 °F
Superheat = 0 °F

For each additional 10 °F of superheat above 40 °F, the table capacities must be reduced by 1%.

When the valve is used in a hot gas defrost circuit, evaporator temperature affects the capacity. When the evaporator temperature differs from 40 °F, adjust the table capacities by multiplying them by the appropriate correction factor found in the following table.

Metric conversions

1 psi = 0.07 bar
 $\frac{5}{9}(t_1 \text{ °F} - 32) = t_2 \text{ °C}$
1 TR = 3.5 kW

Type	Condensing temperature t_c [°F]	Hot gas capacity Q_h [lb/min] at pressure drop across valve Δp [psi]							
		Hot gas temperature t_h 140 °F							
		5	15	25	40	60	80	100	120
R404A/507 (continued)									
EVR 25	80	48.75	81.56	101.57	121.40	137.14	145.03	147.24	147.24
	100	58.50	98.72	124.07	150.54	173.94	188.79	197.59	201.68
	120	71.17	120.84	152.85	187.37	219.72	242.45	258.47	269.34
EVR 32	80	83.32	139.38	173.57	207.46	234.36	247.84	251.62	251.62
	100	99.97	168.69	212.02	257.26	297.24	322.61	337.66	344.65
	120	121.63	206.50	261.20	320.19	375.48	414.31	441.69	460.27
EVR 40	80	120.52	201.61	251.06	300.10	339.00	358.50	363.98	363.98
	100	144.61	244.01	306.69	372.13	429.95	466.66	488.42	498.54
	120	175.93	298.70	377.83	463.16	543.13	599.31	638.91	665.78

Correction factors for t_h and t_e

t_e [°F]	-40	-20	0	20	40	50
Factor	1.18	1.14	1.09	1.04	1	0.97

Data sheet | Solenoid valve, types EVR 2 - EVR 40 Version 2

**Extended capacity
Hot gas**

Type	Condensing temperature t_c [°F]	Hot gas capacity Q_h [lb/min] at pressure drop across valve Δp [psi]							
		Hot gas temperature t_h 140 °F							
		5	15	25	40	60	80	100	120
R410A									
EVR 2	80	0.74	1.26	1.58	1.92	2.23	2.43	2.55	2.61
	100	0.90	1.52	1.93	2.37	2.78	3.08	3.30	3.45
	120	1.09	1.87	2.38	2.94	3.49	3.91	4.23	4.48
EVR 3	80	1.34	2.26	2.85	3.46	4.01	4.37	4.59	4.70
	100	1.61	2.74	3.47	4.26	5.01	5.55	5.94	6.21
	120	1.97	3.36	4.28	5.29	6.29	7.04	7.62	8.07
EVR 4	80	3.37	5.70	7.17	8.71	10.10	11.00	11.55	11.84
	100	4.06	6.90	8.74	10.73	12.62	13.98	14.95	15.65
	120	4.96	8.47	10.77	13.33	15.84	17.72	19.19	20.33
EVR 6	80	4.41	7.46	9.38	11.41	13.22	14.39	15.12	15.49
	100	5.31	9.03	11.44	14.05	16.52	18.29	19.57	20.48
	120	6.49	11.08	14.10	17.44	20.73	23.20	25.11	26.61
EVR 8	80	5.26	8.88	11.17	13.59	15.74	17.14	18.00	18.45
	100	6.33	10.75	13.62	16.73	19.68	21.79	23.31	24.39
	120	7.73	13.20	16.79	20.78	24.69	27.63	29.91	31.69
EVR 10	80	9.27	15.67	19.71	23.97	27.77	30.24	31.76	32.55
	100	11.16	18.97	24.03	29.52	34.72	38.44	41.12	43.02
	120	13.63	23.28	29.62	36.65	43.55	48.74	52.76	55.91
EVR 15	80	14.28	24.13	30.36	36.91	42.77	46.57	48.92	50.14
	100	17.19	29.21	37.00	45.46	53.47	59.19	63.33	66.26
	120	21.00	35.86	45.62	56.45	67.07	75.06	81.26	86.10
EVR 18	80	18.69	31.58	39.74	48.32	55.98	60.96	64.03	65.63
	100	22.50	38.24	48.44	59.51	69.99	77.49	82.91	86.74
	120	27.49	46.94	59.72	73.89	87.80	98.26	106.37	112.71
EVR 20	80	29.65	50.10	63.04	76.64	88.80	96.69	101.57	104.10
	100	35.68	60.66	76.84	94.39	111.02	122.91	131.51	137.59
	120	43.60	74.45	94.73	117.20	139.26	155.86	168.73	178.78
EVR 22	80	33.82	57.13	71.90	87.41	101.28	110.27	115.84	118.73
	100	40.70	69.18	87.63	107.65	126.62	140.18	149.98	156.91
	120	49.73	84.91	108.04	133.67	158.83	177.76	192.43	203.89

Correction factors

The table values refer to hot gas capacity and are given as a function of condensing temperature t_c and pressure drop Δp across the valve.

Capacities are based on:
Hot gas temperature = 140 °F
Subcooling = 10 °F
Evaporating temperature = 40 °F
Superheat = 0 °F

For each additional 10 °F of superheat above 40 °F, the table capacities must be reduced by 1%.

When the valve is used in a hot gas defrost circuit, evaporator temperature affects the capacity. When the evaporator temperature differs from 40 °F, adjust the table capacities by multiplying them by the appropriate correction factor found in the following table.

Metric conversions

1 psi = 0.07 bar
 $\frac{5}{9}(t_1 \text{ °F} - 32) = t_2 \text{ °C}$
1 TR = 3.5 kW

Correction factors for t_h and t_e

t_e [°F]	-40	-20	0	20	40	50
Factor	1.18	1.14	1.09	1.04	1	0.97

**Extended capacity
Hot gas**
Correction factors

The table values refer to hot gas capacity and are given as a function of condensing temperature t_c and pressure drop Δp across the valve.

Capacities are based on:
Hot gas temperature = 140 °F
Subcooling = 10 °F

Evaporating temperature = 40 °F

Superheat = 0 °F

For each additional 10 °F of superheat above 40 °F, the table capacities must be reduced by 1%.

When the valve is used in a hot gas defrost circuit, evaporator temperature affects the capacity. When the evaporator temperature differs from 40 °F, adjust the table capacities by multiplying them by the appropriate correction factor found in the following table.

Metric conversions

1 psi = 0.07 bar

$\frac{5}{9}(t_1 \text{ °F} - 32) = t_2 \text{ °C}$

1 TR = 3.5 kW

Type	Condensing temperature t_c [°F]	Hot gas capacity Q_h [lb/min] at pressure drop across valve Δp [psi]							
		Hot gas temperature t_h 140 °F							
		5	15	25	40	60	80	100	120
R410A (continued)									
EVR 25	80	48.55	82.01	103.21	125.47	145.38	158.30	166.28	170.43
	100	58.42	99.31	125.79	154.52	181.76	201.22	215.29	225.24
	120	71.38	121.88	155.09	191.88	227.99	255.16	276.23	292.68
EVR 32	80	82.96	140.15	176.37	214.41	248.44	270.51	284.16	291.25
	100	99.83	169.71	214.96	264.06	310.60	343.86	367.91	384.92
	120	121.98	208.29	265.03	327.90	389.61	436.05	472.05	500.16
EVR 40	80	120.01	202.73	255.11	310.15	359.36	391.30	411.03	421.29
	100	144.41	245.49	310.94	381.97	449.29	497.40	532.19	556.78
	120	176.45	301.29	383.36	474.31	563.57	630.74	682.82	723.48

Correction factors for t_h and t_e

t_e [°F]	-40	-20	0	20	40	50
Factor	1.18	1.14	1.09	1.04	1	0.97

Data sheet | Solenoid valve, types EVR 2 - EVR 40 Version 2

**Extended capacity
Hot gas**

Type	Condensing temperature t_c [°F]	Hot gas capacity Q_h [lb/min] at pressure drop across valve Δp [psi]							
		Hot gas temperature t_h 140 °F							
		5	15	25	40	60	80	100	120
R32									
EVR 2	80	0.63	1.07	1.36	1.65	1.93	2.11	2.23	2.30
	100	0.76	1.30	1.65	2.03	2.39	2.66	2.86	3.01
	120	0.92	1.58	2.01	2.50	2.98	3.34	3.63	3.86
EVR 3	80	1.14	1.93	2.44	2.98	3.47	3.80	4.01	4.14
	100	1.37	2.33	2.96	3.65	4.31	4.79	5.15	5.41
	120	1.66	2.85	3.63	4.50	5.36	6.01	6.53	6.94
EVR 4	80	2.88	4.87	6.14	7.50	8.73	9.56	10.11	10.44
	100	3.45	5.88	7.46	9.19	10.85	12.06	12.96	13.62
	120	4.19	7.17	9.13	11.32	13.49	15.14	16.44	17.48
EVR 6	80	3.77	6.38	8.04	9.81	11.43	12.51	13.23	13.66
	100	4.52	7.70	9.77	12.03	14.20	15.78	16.96	17.83
	120	5.49	9.38	11.95	14.82	17.66	19.82	21.52	22.88
EVR 8	80	4.49	7.59	9.58	11.68	13.61	14.90	15.76	16.27
	100	5.38	9.17	11.63	14.32	16.91	18.80	20.20	21.24
	120	6.54	11.18	14.24	17.65	21.03	23.61	25.63	27.25
EVR 10	80	7.91	13.40	16.89	20.61	24.01	26.29	27.80	28.70
	100	9.50	16.17	20.52	25.27	29.84	33.16	35.64	37.46
	120	11.53	19.71	25.12	31.14	37.10	41.64	45.22	48.07
EVR 15	80	12.19	20.63	26.02	31.75	36.97	40.49	42.81	44.21
	100	14.63	24.91	31.60	38.92	45.95	51.08	54.89	57.70
	120	17.76	30.36	38.68	47.95	57.14	64.14	69.65	74.04
EVR 18	80	15.95	27.01	34.06	41.56	48.40	53.01	56.04	57.87
	100	19.15	32.60	41.36	50.95	60.15	66.86	71.85	75.53
	120	23.25	39.75	50.64	62.77	74.79	83.96	91.17	96.92
EVR 20	80	25.30	42.84	54.03	65.92	76.77	84.08	88.90	91.79
	100	30.37	51.71	65.61	80.81	95.41	106.05	113.97	119.81
	120	36.88	63.04	80.32	99.57	118.64	133.17	144.61	153.74
EVR 22	80	28.86	48.85	61.61	75.17	87.56	95.89	101.39	104.68
	100	34.64	58.98	74.83	92.16	108.81	120.95	129.98	136.64
	120	42.06	71.90	91.60	113.56	135.30	151.88	164.93	175.33

Correction factors

The table values refer to hot gas capacity and are given as a function of condensing temperature t_c and pressure drop Δp across the valve.

Capacities are based on:
Hot gas temperature = 140 °F
Subcooling = 10 °F
Evaporating temperature = 40 °F
Superheat = 0 °F

For each additional 10 °F of superheat above 40 °F, the table capacities must be reduced by 1%.

When the valve is used in a hot gas defrost circuit, evaporator temperature affects the capacity. When the evaporator temperature differs from 40 °F, adjust the table capacities by multiplying them by the appropriate correction factor found in the following table.

Metric conversions

1 psi = 0.07 bar
 $\frac{5}{9}(t_1 \text{ °F} - 32) = t_2 \text{ °C}$
1 TR = 3.5 kW

Correction factors for t_h and t_e

t_e [°F]	-40	-20	0	20	40	50
Factor	1.18	1.14	1.09	1.04	1	0.97

**Extended capacity
Hot gas**

Type	Condensing temperature t_c [°F]	Hot gas capacity Q_h [lb/min] at pressure drop across valve Δp [psi]							
		Hot gas temperature t_h 140 °F							
		5	15	25	40	60	80	100	120
R290									
EVR 2	80	0.42	0.70	0.86	1.01	1.11	1.13	1.13	1.13
	100	0.50	0.84	1.04	1.25	1.41	1.49	1.52	1.52
	120	0.59	1.00	1.26	1.52	1.76	1.90	1.99	2.02
EVR 3	80	0.76	1.26	1.56	1.82	2.00	2.03	2.03	2.03
	100	0.90	1.51	1.88	2.25	2.54	2.69	2.73	2.73
	120	1.07	1.80	2.26	2.74	3.16	3.42	3.58	3.64
EVR 4	80	1.92	3.18	3.92	4.59	5.03	5.12	5.12	5.12
	100	2.27	3.80	4.74	5.66	6.40	6.77	6.88	6.88
	120	2.69	4.53	5.69	6.90	7.96	8.62	9.01	9.18
EVR 6	80	2.52	4.17	5.13	6.01	6.58	6.70	6.70	6.70
	100	2.97	4.98	6.20	7.41	8.38	8.86	9.01	9.01
	120	3.52	5.93	7.45	9.03	10.42	11.29	11.79	12.01
EVR 8	80	3.00	4.96	6.11	7.16	7.83	7.98	7.98	7.98
	100	3.54	5.93	7.38	8.83	9.98	10.56	10.73	10.73
	120	4.19	7.06	8.87	10.75	12.41	13.44	14.04	14.30
EVR 10	80	5.29	8.76	10.78	12.63	13.82	14.08	14.08	14.08
	100	6.25	10.46	13.02	15.57	17.60	18.62	18.92	18.92
	120	7.39	12.46	15.65	18.97	21.89	23.72	24.77	25.23
EVR 15	80	8.15	13.49	16.60	19.44	21.29	21.68	21.68	21.68
	100	9.62	16.10	20.06	23.98	27.11	28.68	29.14	29.14
	120	11.38	19.19	24.10	29.22	33.71	36.52	38.16	38.86
EVR 18	80	10.67	17.65	21.72	25.45	27.87	28.38	28.38	28.38
	100	12.60	21.08	26.26	31.40	35.48	37.55	38.15	38.15
	120	14.90	25.12	31.55	38.25	44.12	47.81	49.95	50.87
EVR 20	80	16.93	28.00	34.46	40.37	44.20	45.02	45.02	45.02
	100	19.98	33.44	41.65	49.80	56.28	59.56	60.51	60.51
	120	23.63	39.85	50.05	60.67	69.99	75.84	79.23	80.69
EVR 22	80	19.30	31.94	39.30	46.05	50.41	51.35	51.35	51.35
	100	22.79	38.13	47.50	56.79	64.19	67.92	69.01	69.01
	120	26.95	45.44	57.08	69.19	79.82	86.49	90.35	92.02

Correction factors

The table values refer to hot gas capacity and are given as a function of condensing temperature t_c and pressure drop Δp across the valve.

Capacities are based on:
 Hot gas temperature = 140 °F
 Subcooling = 10 °F
 Evaporating temperature = 40 °F
 Superheat = 0 °F

For each additional 10 °F of superheat above 40 °F, the table capacities must be reduced by 1%.

When the valve is used in a hot gas defrost circuit, evaporator temperature affects the capacity. When the evaporator temperature differs from 40 °F, adjust the table capacities by multiplying them by the appropriate correction factor found in the following table.

Metric conversions

1 psi = 0.07 bar
 $\frac{5}{9}(t_1 \text{ °F} - 32) = t_2 \text{ °C}$
 1 TR = 3.5 kW

Correction factors for t_h and t_e

t_e [°F]	-40	-20	0	20	40	50
Factor	1.18	1.14	1.09	1.04	1	0.97

Data sheet | Solenoid valve, types EVR 2 - EVR 40 Version 2
**Extended capacity
Hot gas**

Type	Condensing temperature t_c [°F]	Hot gas capacity Q_h [lb/min] at pressure drop across valve Δp [psi]							
		Hot gas temperature t_h 140 °F							
		5	15	25	40	60	80	100	120
R600a									
EVR 2	80	0.28	0.42	0.46	0.46	–	–	–	–
	100	0.33	0.52	0.61	0.64	0.64	–	–	–
	120	0.40	0.64	0.76	0.85	0.86	0.86	–	–
EVR 3	80	0.50	0.75	0.82	0.83	–	–	–	–
	100	0.60	0.94	1.09	1.14	1.14	–	–	–
	120	0.71	1.15	1.38	1.53	1.55	1.55	–	–
EVR 4	80	1.25	1.89	2.08	2.08	–	–	–	–
	100	1.51	2.37	2.75	2.88	2.88	–	–	–
	120	1.80	2.90	3.47	3.85	3.91	3.91	–	–
EVR 6	80	1.64	2.47	2.72	2.73	–	–	–	–
	100	1.98	3.10	3.59	3.77	3.77	–	–	–
	120	2.36	3.80	4.54	5.04	5.12	5.12	–	–
EVR 8	80	1.95	2.95	3.24	3.25	–	–	–	–
	100	2.35	3.70	4.28	4.49	4.49	–	–	–
	120	2.81	4.52	5.40	6.01	6.10	6.10	–	–
EVR 10	80	3.45	5.20	5.71	5.73	–	–	–	–
	100	4.15	6.52	7.55	7.92	7.92	–	–	–
	120	4.95	7.98	9.53	10.60	10.76	10.76	–	–
EVR 15	80	5.31	8.00	8.80	8.82	–	–	–	–
	100	6.40	10.04	11.63	12.19	12.19	–	–	–
	120	7.63	12.29	14.68	16.32	16.57	16.57	–	–
EVR 18	80	6.95	10.48	11.52	11.55	–	–	–	–
	100	8.37	13.15	15.22	15.96	15.96	–	–	–
	120	9.98	16.09	19.22	21.37	21.70	21.70	–	–
EVR 20	80	11.02	16.62	18.27	18.32	–	–	–	–
	100	13.28	20.86	24.15	25.32	25.32	–	–	–
	120	15.83	25.52	30.48	33.89	34.41	34.41	–	–
EVR 22	80	12.57	18.96	20.83	20.89	–	–	–	–
	100	15.15	23.79	27.54	28.88	28.88	–	–	–
	120	18.06	29.10	34.77	38.65	39.25	39.25	–	–

Correction factors

The table values refer to hot gas capacity and are given as a function of condensing temperature t_c and pressure drop Δp across the valve.

Capacities are based on:
Hot gas temperature = 140 °F
Subcooling = 10 °F
Evaporating temperature = 40 °F
Superheat = 0 °F

For each additional 10 °F of superheat above 40 °F, the table capacities must be reduced by 1%.

When the valve is used in a hot gas defrost circuit, evaporator temperature affects the capacity. When the evaporator temperature differs from 40 °F, adjust the table capacities by multiplying them by the appropriate correction factor found in the following table.

Metric conversions

1 psi = 0.07 bar
 $\frac{5}{9}(t_1 \text{ °F} - 32) = t_2 \text{ °C}$
1 TR = 3.5 kW

Correction factors for t_h and t_e

t_e [°F]	-40	-20	0	20	40	50
Factor	1.18	1.14	1.09	1.04	1	0.97

ENGINEERING
TOMORROW



Danfoss can accept no responsibility for possible errors in catalogues, brochures and other printed material. Danfoss reserves the right to alter its products without notice. This also applies to products already on order provided that such alterations can be made without subsequential changes being necessary in specifications already agreed. All trademarks in this material are property of the respective companies. Danfoss and the Danfoss logotype are trademarks of Danfoss A/S. All rights reserved.
